

# Installation Manual

## Middle Static Pressure Duct Type

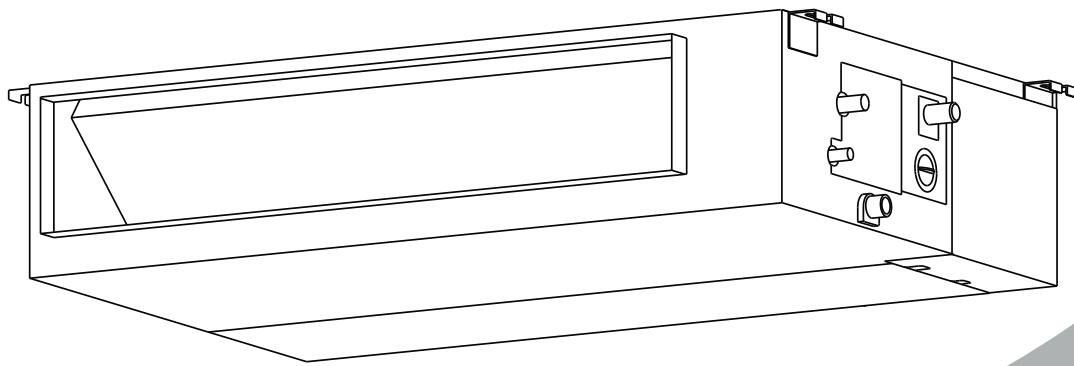

MODEL:

|              |            |
|--------------|------------|
| CH-24LCDTU/I | CH-24LCU/O |
| CH-36LCDTU/I | CH-36LCU/O |
| CH-48LCDTU/I | CH-48LCU/O |

**IMPORTANT NOTE:**

Read this manual carefully before installing or operating your new air conditioning unit. Make sure to save this manual for future reference.



# Table of Contents

## Installation Manual

|   |                             |    |
|---|-----------------------------|----|
| 1 | Accessories .....           | 04 |
| 2 | Safety Precautions .....    | 05 |
| 3 | Installation Overview ..... | 06 |

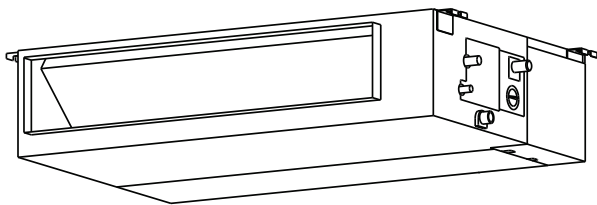
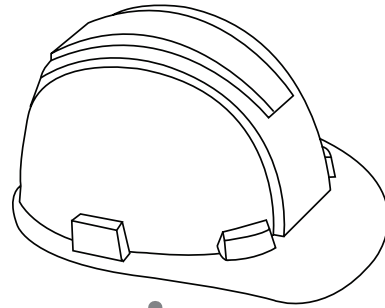

|   |  |    |
|---|--|----|
| 4 | Indoor Unit Installation .....                 | 07 |
|   | a. Indoor Unit Parts .....                     | 07 |
|   | b. Indoor Unit Installation Instructions ..... | 08 |

|   |   |    |
|---|---|----|
| 5 | Outdoor Unit Installation .....                 | 12 |
|   | a. Outdoor Unit Installation Instructions ..... | 12 |
|   | b. Outdoor Unit Types and Specifications .....  | 13 |
|   | c. Notes on Drilling Hole in Wall .....         | 14 |

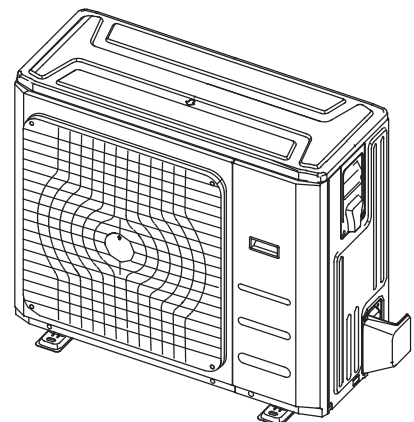

|   |                              |    |
|---|------------------------------|----|
| 6 | Drainpipe Installation ..... | 15 |
|---|------------------------------|----|

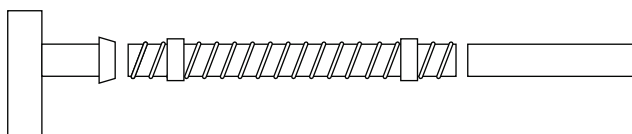

**7 Refrigerant Piping Connection..... 17**

A. Notes on Pipe Length and Elevation ..... 17

B. Refrigerant Piping Connection Instructions ...18

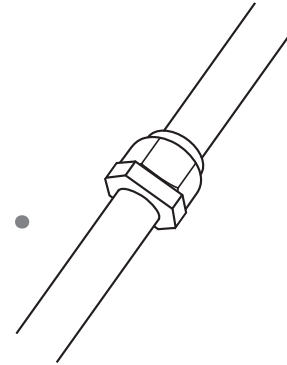
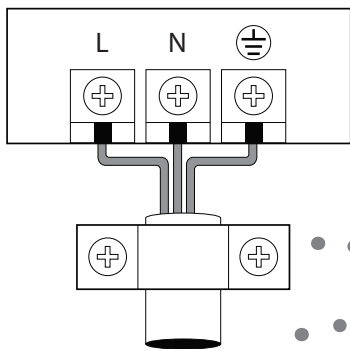

**8 Wiring..... 20**

a. Outdoor Unit Wiring ..... 20

b. Indoor Unit Wiring ..... 21

c. Power Specifications ..... 23

**9 Air Evacuation..... 25**

a. Evacuation Instructions ..... 25

b. Note on Adding Refrigerant ..... 26

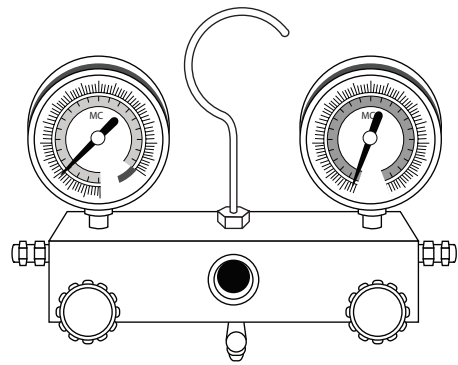









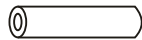

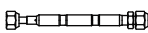

**10 Test Run..... 27**

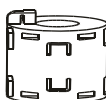
# Accessories

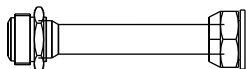
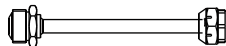
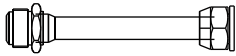
# 1

The air conditioning system comes with the following accessories. Use all of the installation parts and accessories to install the air conditioner. Improper installation may result in water leakage, electrical shock and fire, or equipment failure.

|  | NAME  | SHAPE   | QUANTITY              |
|--|---|---|-----------------------|
| Tubing & Fittings                                | Soundproof / insulation sheath  |                  | 2                     |
|  | Seal sponge (some models)   |                  | 1                     |
|  | Orifice (some models)   |                  | 1                     |
| Drainpipe Fittings<br>(for cooling & heating)    | Drain joint (some models)   |                  | 1                     |
|  | Seal ring (some models)   |                  | 1                     |
| EMC Magnetic Ring<br>(some models)               | Magnetic ring<br>(wrap the electric wires S1 & S2 ( P & Q & E )<br>around the magnetic ring twice)  | <br>S1&S2(P&Q&E) | 1                     |
|  | Magnetic ring<br>(Hitch on the connective cable between the indoor<br>unit and outdoor unit after installation.)  |                 | 1                     |
| Ø0.5in-Ø0.63in                                   | Owner's manual  |                | 1                     |
|  | Installation manual   |                | 1                     |
|  | Transfer connector (Ø0.5in-Ø0.63in)/(Ø12.7-Ø15.9)<br>(Packed with the indoor unit )<br>NOTE: Pipe size may differ from appliance to<br>appliance. To meet different pipe size requirements,<br>sometimes the pipe connections need a transfer<br>connector installed on the outdoor unit .                                      |                | 1<br>(on some models) |
|  | Transfer connector (Ø0.25in-Ø0.375in)/(Ø6.35-<br>Ø9.52)(Packed with the indoor unit) NOTE: Pipe size<br>may differ from appliance to appliance. To meet<br>different pipe size requirements, sometimes the<br>pipe connections need a transfer connector<br>installed on the outdoor unit .                                     |                | 1<br>(on some models) |
|  | Transfer connector (Ø0.375in-Ø0.5in)/(Ø9.52-Ø12.7)<br>(Packed with the indoor unit, used for multi-type<br>models only ) NOTE: Pipe size may differ from<br>appliance to appliance. To meet different pipe size<br>requirements, sometimes the pipe connections<br>need a transfer connector installed on the outdoor<br>unit . |                | 1<br>(on some models) |
|  | Connecting wire for display 78" in (2m)   |                | 1(on some models)     |
|  | Cord protection rubber ring   |                | 1(on some models)     |
| Display panel<br>*Just for testing purposes only |    | 1(on some models)   |                       |

## Optional accessories

- There are two types of remote controls: wired and wireless.  
Select a remote control based on customer preferences and requirements and install in an appropriate place.  
Refer to catalogues and technical literature for guidance on selecting a suitable remote control.

## Read Safety Precautions Before Installation

Incorrect installation due to ignoring instructions can cause serious damage or injury. The seriousness of potential damage or injuries is classified as either a **WARNING** or **CAUTION**.



**WARNING**

Failure to observe a warning may result in death. The product must be installed by installers or contractors who are licensed HVAC professionals and in compliance with all local, state and provincial laws.



**CAUTION**

Failure to observe a caution may result in injury or equipment damage.

### **WARNING**

- **Carefully read the Safety Precautions before installation.**
- In certain functional environments, such as kitchens, server rooms, etc., the use of specially designed air-conditioning units is highly recommended.
- **Only trained and certified technicians should install, repair and service this air conditioning unit.**  
Improper installation may result in electrical shock, short circuit, leaks, fire or other damage to the equipment and personal property.
- **Strictly follow the installation instructions set forth in this manual.**  
Improper installation may result in electrical shock, short circuit, leaks, fire or other damage to the equipment.
- Before you install the unit, consider strong winds, typhoons and earthquakes that might affect your unit and locate it accordingly. Failure to do so could cause the equipment to fail.
- After installation, ensure there are no refrigerant leaks and that the unit is operating properly. Refrigerant is both toxic and flammable and poses a serious health and safety risk.

### **Note about Fluorinated Gasses**

1. This air-conditioning unit contains fluorinated gasses. For specific information on the type of gas and the amount, please refer to the relevant label on the unit itself.
2. Installation, service, maintenance and repair of this unit must be performed by a certified technician.
3. Product uninstallation and recycling must be performed by a certified technician.
4. If the system has a leak-detection system installed, it must be checked for leaks at least every 12 months.
5. When the unit is checked for leaks, proper record-keeping of all checks is strongly recommended.

# Installation Overview

3

## INSTALLATION ORDER

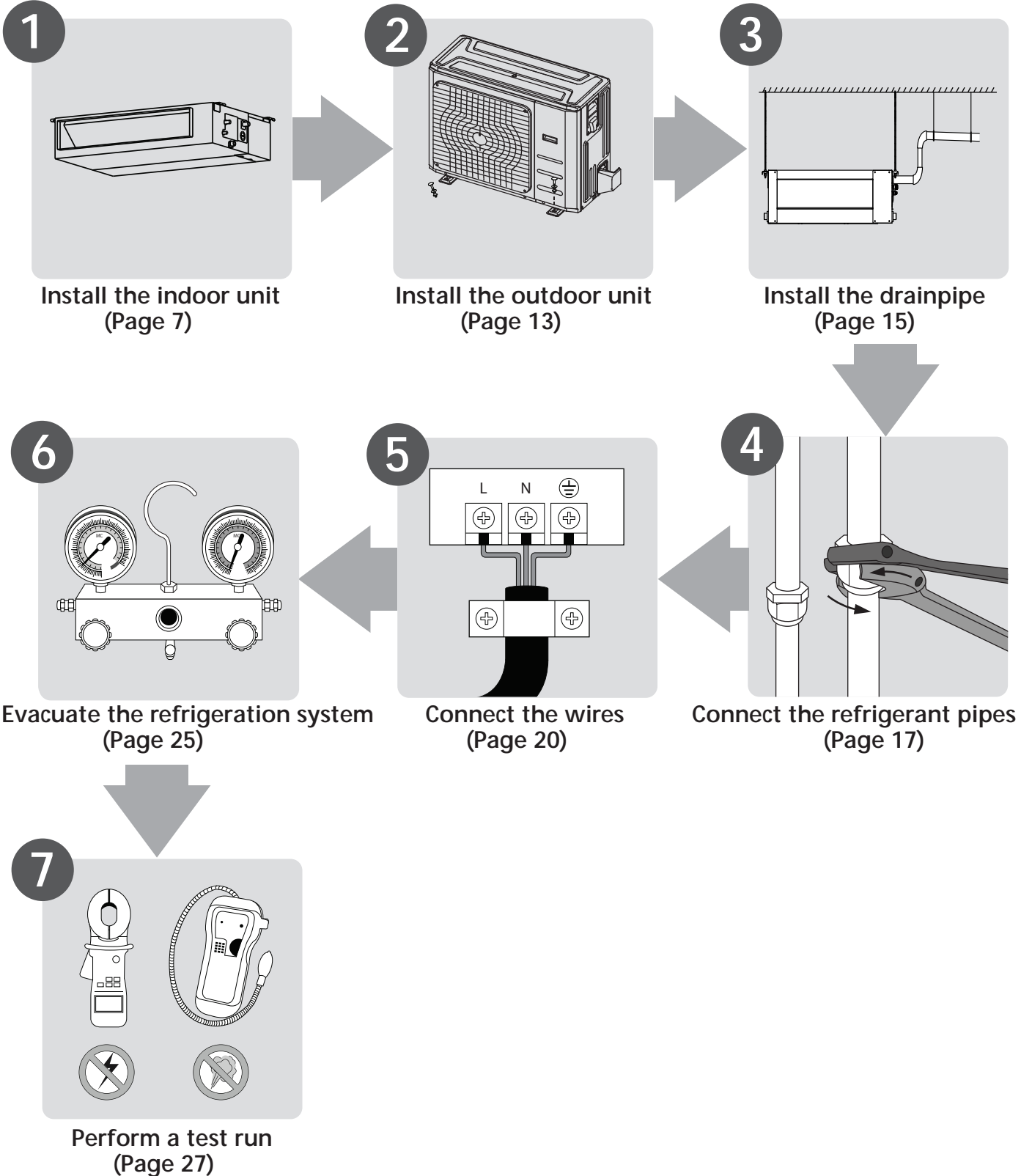

## Indoor Unit Parts

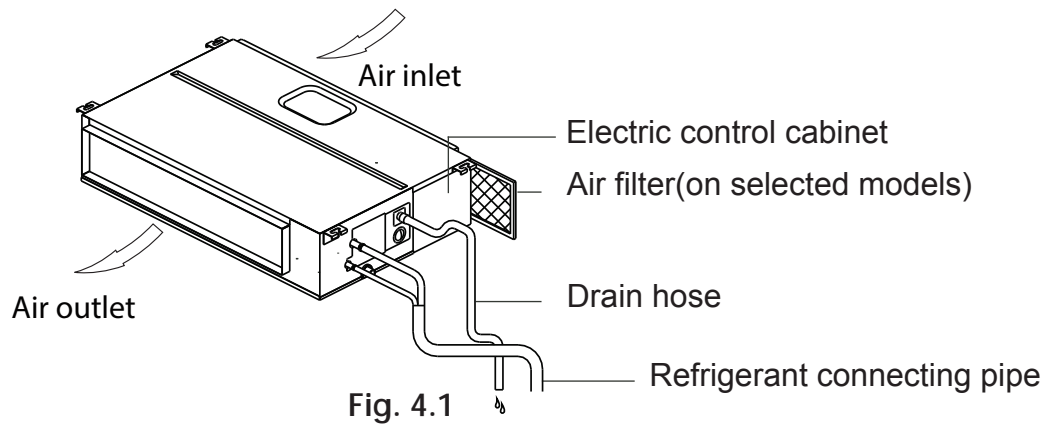

Fig. 4.1

## Safety Precautions

### **⚠ WARNING**

- Securely install the indoor unit on a structure that can sustain its weight. If the structure is too weak, the unit may fall causing personal injury, unit and property damage, or even death
- **DO NOT** install the indoor unit in a bathroom or laundry room as excessive moisture can short the unit and corrode the wiring.

### **⚠ CAUTION**

- Install the indoor and outdoor units, cables and wires at least 1m (3.2') from televisions or radios to prevent static or image distortion. Depending on the appliances, a 1m (3.2') distance may not be sufficient.
- If the indoor unit is installed on a metal part of the building, it must be grounded.

## Indoor Unit Installation Instructions

### Step 1: Select installation location

The indoor unit should be installed in a location that meets the following requirements:

- ☑ Enough room for installation and maintenance.
- ☑ Enough room for the connecting pipe and drainpipe.
- ☑ The ceiling is horizontal and its structure can sustain the weight of the indoor unit.
- ☑ The air inlet and outlet are not impeded.
- ☑ The airflow can fill the entire room.
- ☑ There is no direct radiation from heaters.
- ☑ It is embeded installation.

### **⚠ CAUTION**

**DO NOT** install the unit in the following locations:

- ⊘ Where oil drilling or fracking is taking place.
- ⊘ Coastal areas with high salt content in the air
- ⊘ Near geothermal activity and corrosive gas
- ⊘ Buildings that may experience power fluctuations
- ⊘ Enclosed spaces
- ⊘ Areas with strong electromagnetic waves
- ⊘ Areas that store flammable materials or gas
- ⊘ Rooms with high humidity, such as bathrooms or laundry rooms

## Installation place

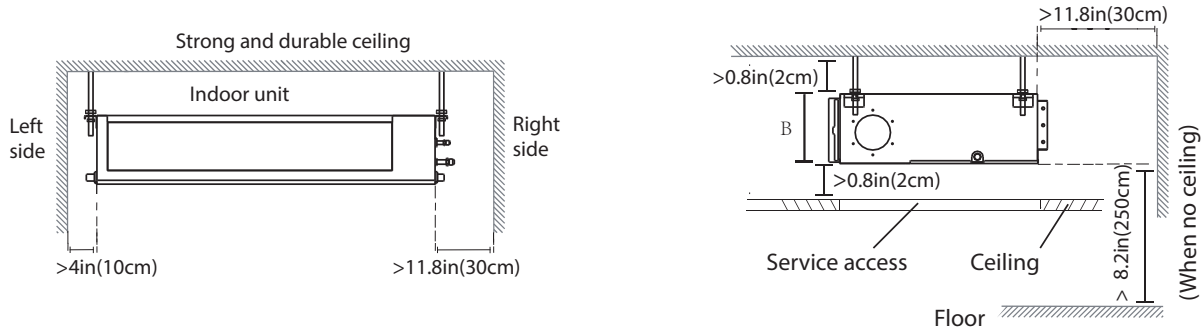

## Maintenance space

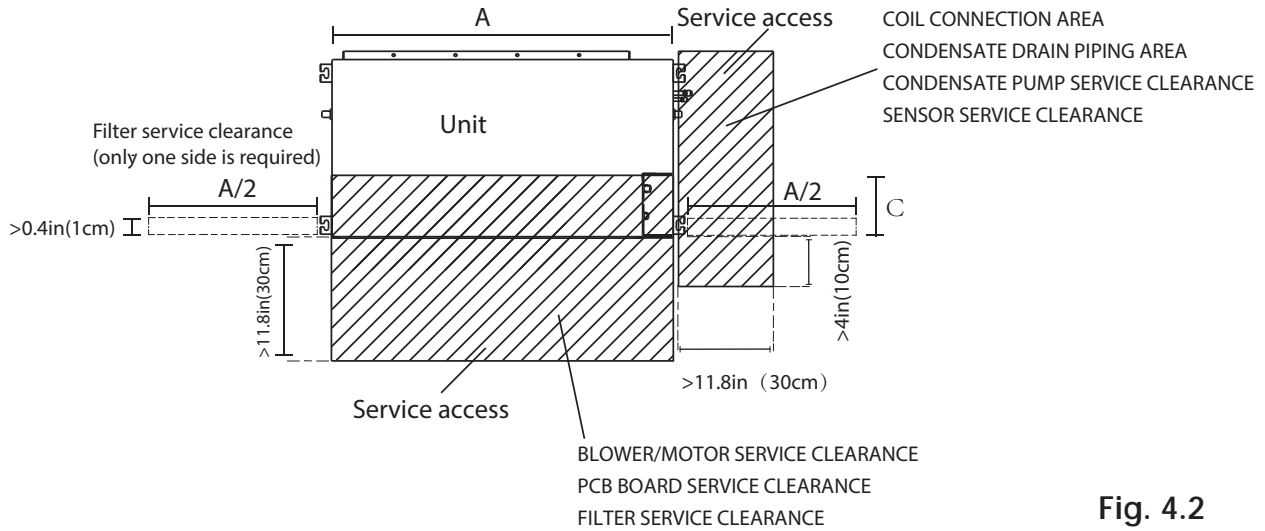

Fig. 4.2

TABLE

| Capacity(KBtu) | A              | B             | C             |
|----------------|----------------|---------------|---------------|
| 9K             | 27.56in(70cm)  | 8.27in(21cm)  | 11.81in(30cm) |
| 12K            | 27.56in(70cm)  | 8.27in(21cm)  | 11.81in(30cm) |
| 18K            | 36.22in(92cm)  | 8.27in(21cm)  | 11.81in(30cm) |
| 24K            | 36.22in(92cm)  | 10.63in(27cm) | 11.81in(30cm) |
| 36K            | 44.88in(114cm) | 10.63in(27cm) | 11.81in(30cm) |
| 48K            | 47.24in(120cm) | 11.81in(30cm) | 15.75in(40cm) |

## Step 2: Hang indoor unit.

1. Please refer to the following diagrams to locate the four positioning screw bolt holes on the ceiling. Be sure to mark the paces where you will drill ceiling hook holes.

Air outlet dimensions

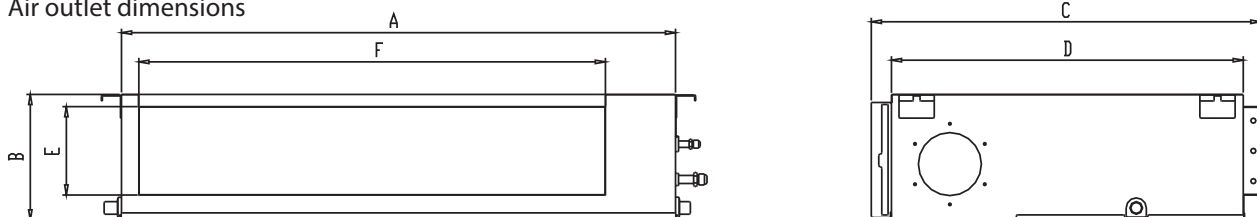

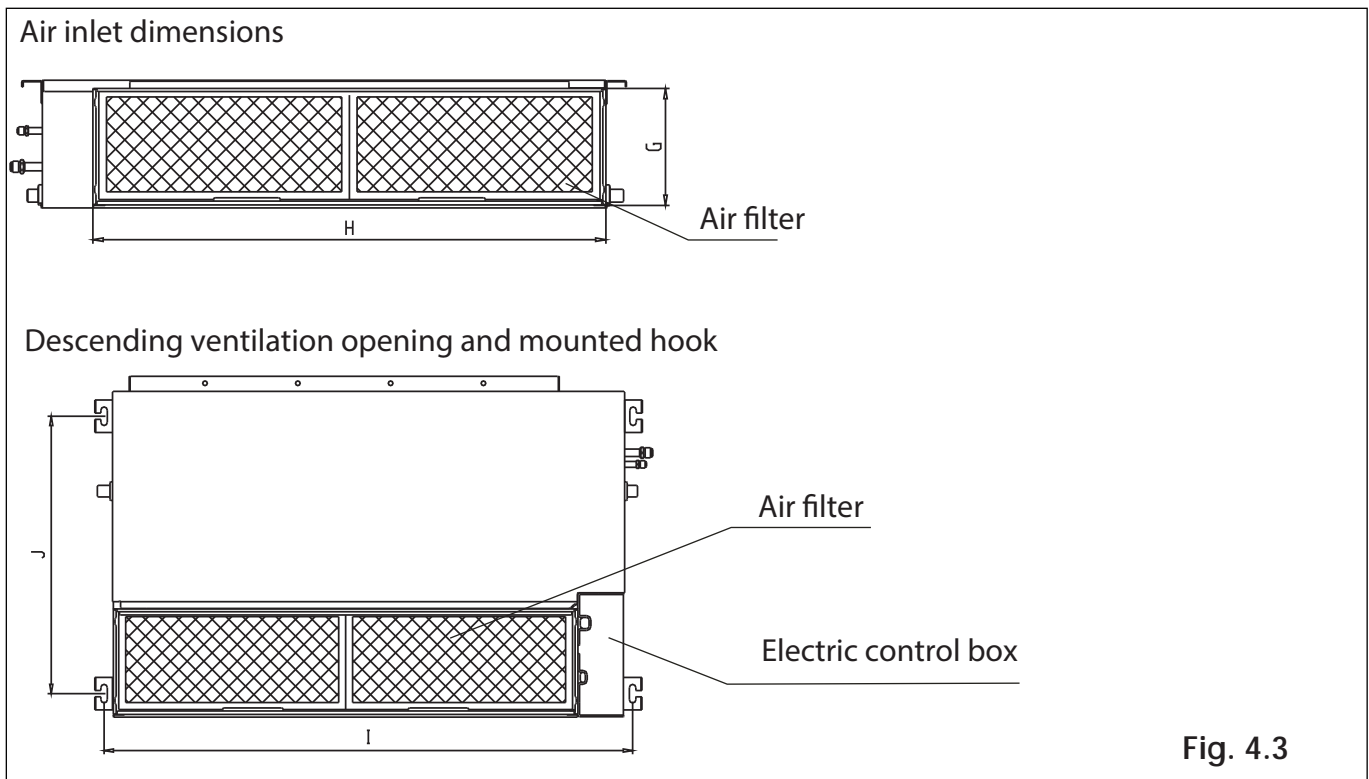

Fig. 4.3

Table.4-1

(unit: in/mm)

| MODEL<br>(Btu/h) | Outline dimension |          |          |          | air outlet opening size |           | air return opening size |           | Size of mounted lug |          |
|------------------|-------------------|----------|----------|----------|-------------------------|-----------|-------------------------|-----------|---------------------|----------|
|                  | A                 | B        | C        | D        | E                       | F         | G                       | H         | I                   | J        |
| 18K              | 34.6/880          | 8.3/210  | 26.5/674 | 23.6/600 | 5.4/136                 | 27.8/706  | 7.5/190                 | 30.8/782  | 36.2/920            | 20/508   |
| 24K              | 43.3/1100         | 9.8/249  | 30.5/774 | 27.6/700 | 6.9/175                 | 36.5/926  | 8.9/228                 | 39.4/1001 | 44.9/1140           | 23.5/598 |
| 30K~36K          | 53.5/1360         | 9.8/249  | 30.5/774 | 27.6/700 | 6.9/175                 | 46.7/1186 | 8.9/228                 | 49.6/1261 | 55.1/1400           | 23.5/598 |
| 36K~60K          | 47.2/1200         | 11.8/300 | 34.4/874 | 31.5/800 | 8.9/227                 | 41.1/1044 | 11/280                  | 43.3/1101 | 48.8/1240           | 27.4/697 |

**Wood**

Place the wood mounting across the roof beam, then install the hanging screw bolts.(See Fig.4.4)

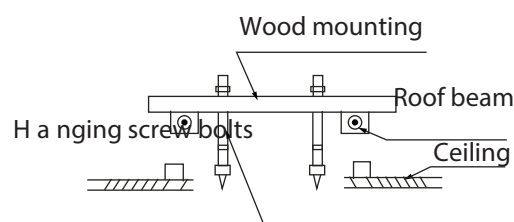

Fig. 4.4

**New concrete bricks**

Inlay or embed the screw bolts. (See Fig. 4.5)

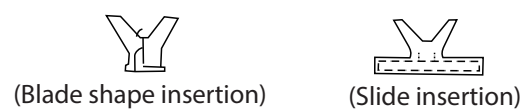

Fig. 4.5

**Original concrete bricks**

Use an embedding screw bolt, crock, and stick harness. (See Fig.4.6)

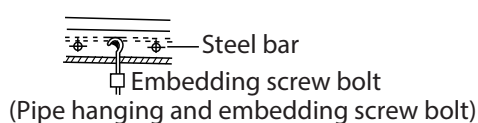

Fig. 4.6

**Steel Roof beam structure**

Install and use the supporting steel angle. (See Fig.4.7)

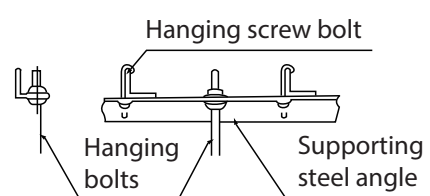

Fig. 4.7

**! CAUTION**

The unit body must be completely aligned with the hole. Ensure that the unit and the hole are the same size before moving on.

2. Install and fit pipes and wires after you have finished installing the main body. When choosing where to start, determine the direction of the pipes to be drawn out. Especially in cases where there is a ceiling involved, align the refrigerant pipes, drain pipes, and indoor and outdoor lines with their connection points before mounting the unit.
3. Install hanging screw bolts.
  - Cut off the roof beam.
  - Strengthen the point at which the cut was made. Consolidate the roof beam.
4. After you select an installation location, align the refrigerant pipes, drain pipes, as well as indoor and outdoor wires with their connection points before mounting the unit.
5. Drill 4 holes 4" (10cm) deep at the ceiling hook positions in the internal ceiling. Be sure to hold the drill at a 90° angle to the ceiling.
6. Secure the bolt using the washers and nuts provided.
7. Install the four suspension bolts.
8. Mount the indoor unit with at least two people to lift and secure it. Insert suspension bolts into the unit's hanging holes. Fasten them using the washers and nuts provided. (See Fig. 4.8).

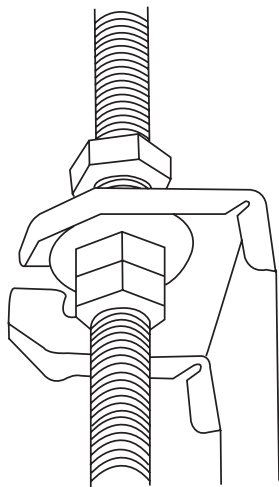

Fig. 4.8

9. Mount the indoor unit onto the hanging screw bolts with a block. Position the indoor unit flat using a level indicator to prevent leaks. (See Fig. 4.9).

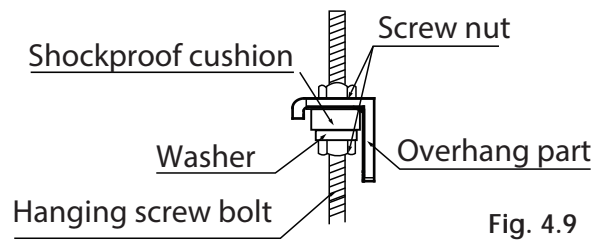

Fig. 4.9

**NOTE:** Confirm the minimum drain tilt is 1/100 or more.

**Step 3: Duct and accessories installation**

1. Install the filter (optional) according to the size of the air inlet.
2. Install the canvas tie-in between the body and the duct.
3. The air inlet and air outlet duct should be far enough apart enough to avoid air passage short-circuit.
4. Connect the duct according to the following diagram:

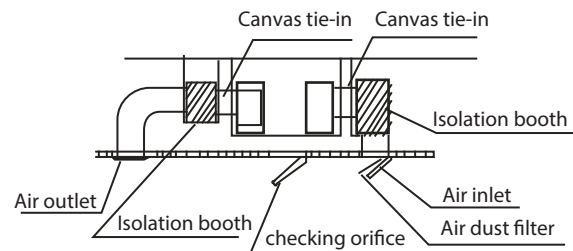

Fig. 4.10

5. Refer to the following static pressure guidelines when installing the indoor unit.

Table.4-2

| MODEL (Btu/h) | Static Pressure (Pa/in.wg) |
|---------------|----------------------------|
| 18K           | 0~100/0~0.4                |
| 24K           | 0~160/0~0.64               |
| 30K~36K       | 0~160/0~0.64               |
| 42K~60K       | 0~160/0~0.64               |

Change the fan motor static pressure according to external duct static pressure.

- NOTE:**
1. Do not place the connecting duct weight on the indoor unit.
  2. When connecting the duct, use a nonflammable canvas tie-in to prevent vibrating.
  3. Insulation foam must be wrapped outside the duct to avoid condensate. An internal duct underlayer can be added to reduce noise, if the end-user requires.

### Step 4: Adjust the air inlet direction (from rear side to under-side).

1. Take off the ventilation panel and flange.

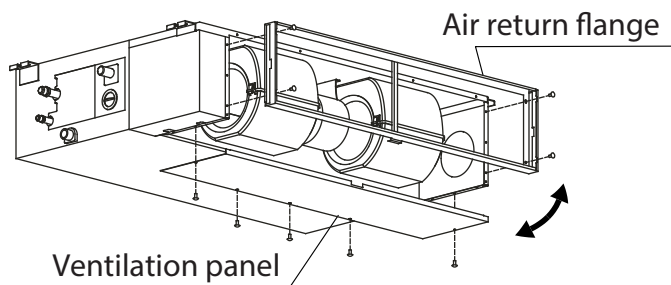

Fig. 4.11

2. Change the mounting positions of the ventilation panel and air return flange.

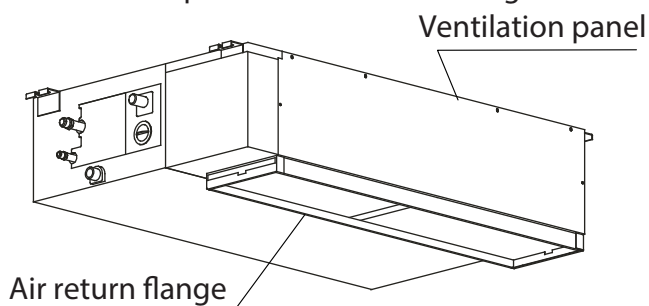

Fig. 4.12

3. When installing the filter mesh, fit it into the flange as illustrated in the following figure.

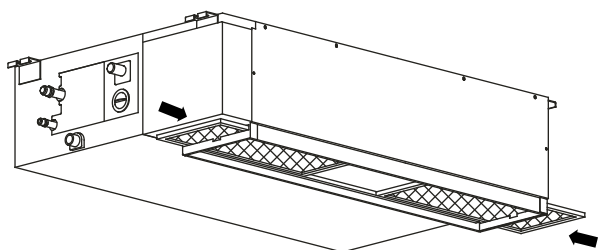

Fig. 4.13

**NOTE:** All the figures in this manual are for demonstration purposes only. The air conditioner you have purchased may be slightly different in design, though similar in shape.

### Step 5: Fresh air duct installation

Dimension :

Duct joint for fresh air

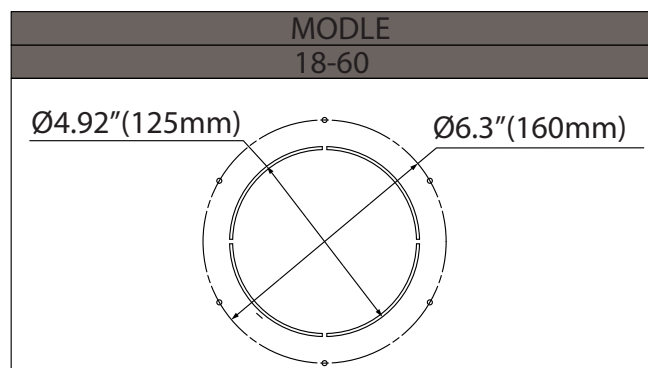
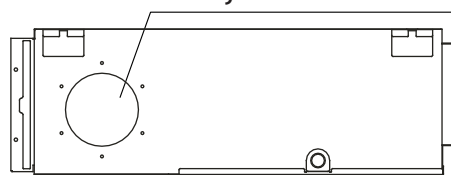

Fig. 4.14

### Step 6: Motor and drain pump maintenance

(the rear ventilated panel is used as an example)

#### Motor maintain:

1. Take off the ventilated panel.
2. Take off the blower housing.
3. Take off the motor.

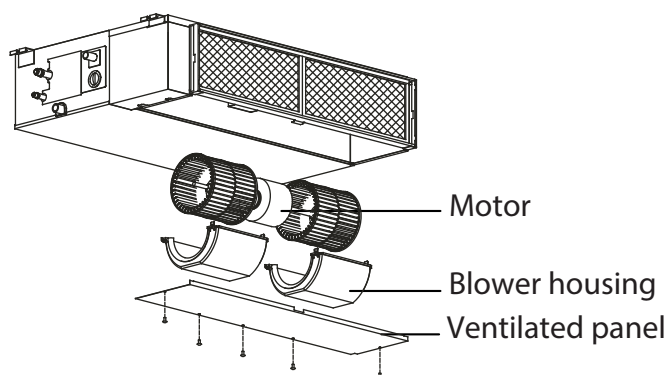

Fig. 4.15

#### Pump maintainance:

1. Remove four screws from the drain pump.
2. Unplug the pump power supply and water level switch cable.
3. Detach the pump.

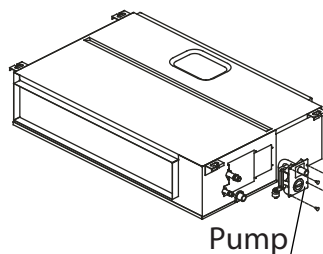

Fig. 4.16

# Outdoor Unit Installation

# 5

## Outdoor Unit Installation Instructions

Outdoor Unit  
Installation

### Step 1: Select installation location.

The outdoor unit should be installed in the location that meets the following requirements:

- ❑ Place the outdoor unit as close to the indoor unit as possible.
- ❑ Ensure that there is enough room for installation and maintenance.
- ❑ The air inlet and outlet must not be obstructed or exposed to strong wind.
- ❑ Ensure the location of the unit will not be subject to snowdrifts, accumulation of leaves or other seasonal debris. If possible, provide an awning for the unit. Ensure the awning does not obstruct airflow.
- ❑ The installation area must be dry and well ventilated.
- ❑ There must be enough room to install the connecting pipes and cables and to access them for maintenance.

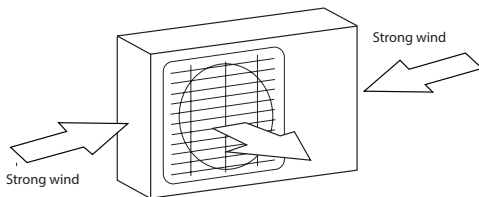

Fig. 5.1

- ❑ The area must be free of combustible gases and chemicals.
- ❑ The pipe length between the outdoor and indoor unit may not exceed the maximum allowable pipe length.
- ❑ If possible, **DO NOT** install the unit where it is exposed to direct sunlight.
- ❑ If possible, make sure the unit is located far away from your neighbors' property so that the noise from the unit will not disturb them.
- ❑ If the location is exposed to strong winds (for example: near a seaside), the unit must be placed against the wall to shelter it from the wind. If necessary, use an awning. (See Fig. 5.1 & 5.2)
- ❑ Install the indoor and outdoor units, cables and wires at least 1 meter from televisions or radios to prevent static or image distortion. Depending on the radio waves, a 3,2" (1 meter) distance may not be enough to eliminate all interference.

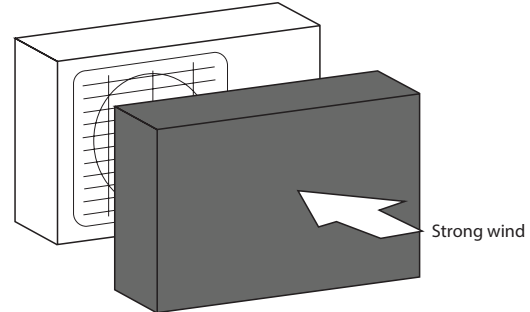

Fig. 5.2

### Step 2: Install outdoor unit.

Fix the outdoor unit with anchor bolts (M10)

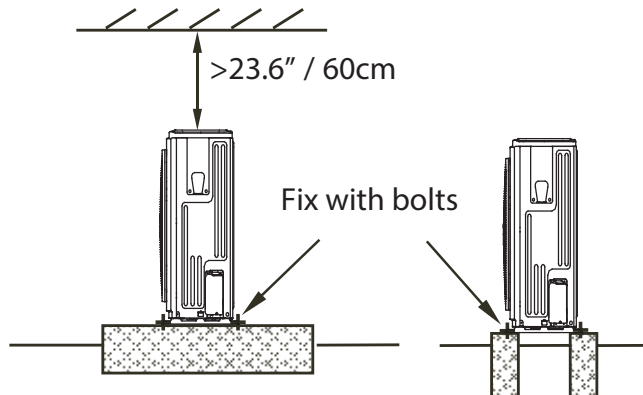

Fig. 5.3

### ! CAUTION

- Be sure to remove any obstacles that may block air circulation.
- Make sure you refer to Length Specifications to ensure there is enough room for installation and maintenance.

### Split Type Outdoor Unit

(Refer to Fig 5.4, 5.5, 5.6, 5.10 and Table 5.1)

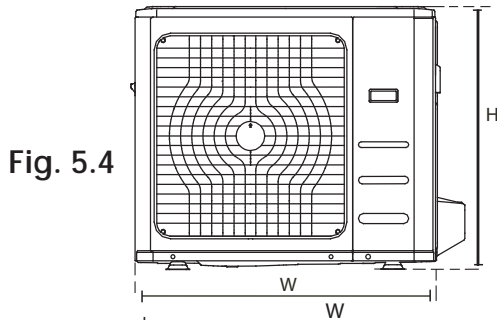

Fig. 5.4

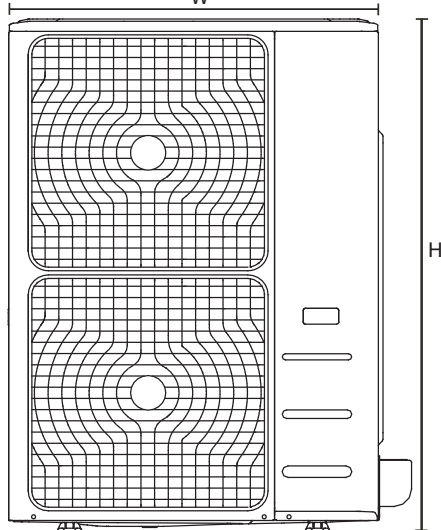

Fig. 5.5

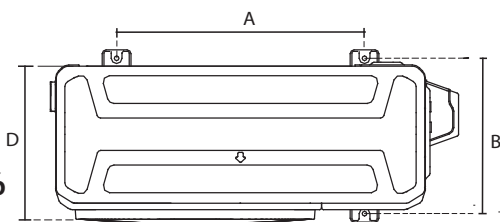

Fig. 5.6

**Table 5.1: Length Specifications of Split Type Outdoor Unit (unit: inch/mm)**

| Outdoor Unit Dimensions<br>W x H x D | Mounting Dimensions |             |
|--------------------------------------|---------------------|-------------|
|                                      | Distance A          | Distance B  |
| 770x555x300 (30.3x21.85x11.81)       | 19.2 (487)          | 11.73 (298) |
| 810x558x310 (31.9x22x12.2)           | 21.6 (549)          | 12.8 (325)  |
| 845x700x320 (33.27x27.5x12.6)        | 22 (560)            | 13.2 (335)  |
| 900x860x315 (35.4x33.85x12.4)        | 23.2 (590)          | 13.1 (333)  |
| 945x810x395 (37.2x31.9x15.55)        | 25.2 (640)          | 15.95 (405) |
| 990x965x345 (38.98x38x13.58)         | 24.58 (624)         | 14.4 (366)  |
| 938x1369x392 (36.93x53.9x15.43)      | 24.96 (634)         | 15.9 (404)  |
| 900x1170x350 (35.4x46x13.8)          | 23.2 (590)          | 14.88 (378) |
| 800x554x333 (31.5x21.8x13.1)         | 20.24 (514)         | 13.39 (340) |
| 845x702x363 (33.27x27.6x14.3)        | 21.26 (540)         | 13.8 (350)  |
| 946x810x420 (37.24x31.9x16.53)       | 26.5 (673)          | 15.87 (403) |
| 946x810x410 (37.24x31.9x16.14)       | 26.5 (673)          | 15.87 (403) |
| 952x1333x410 (37.5x52.5x16.14)       | 24.96 (634)         | 15.9 (404)  |
| 952x1333x415 (37.5x52.5x16.34)       | 24.96 (634)         | 15.9 (404)  |

### Vertical Discharge Type Outdoor Unit

(Refer to Fig 5.7, 5.8, 5.9 and Table 5.2)

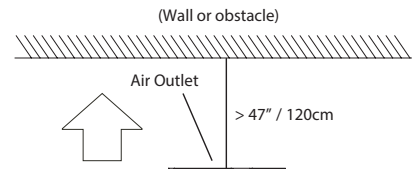

Fig. 5.7

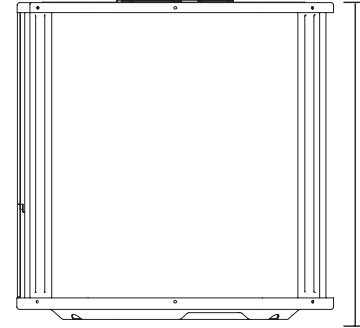

Fig. 5.8

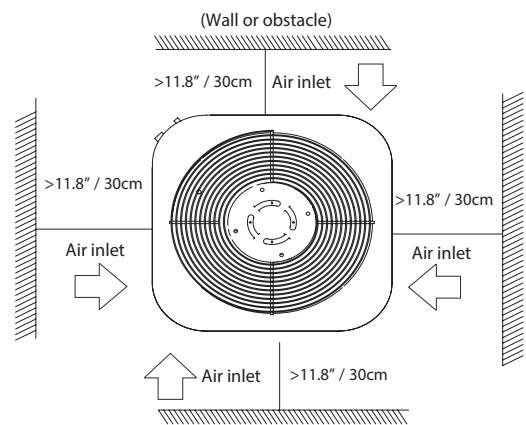
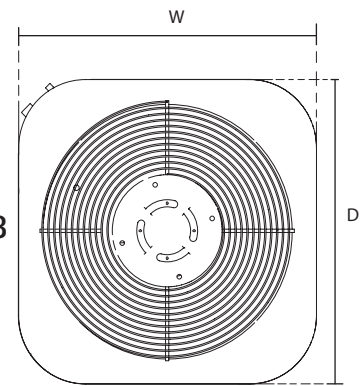

Fig. 5.9

**Table 5.2: Length Specifications of Vertical Discharge Outdoor Unit (unit: inch/mm)**

| MODEL | DIMENSIONS |          |          |
|-------|------------|----------|----------|
|       | W          | H        | D        |
| 18    | 21.8/554   | 25/633   | 21.8/554 |
| 24    | 21.8/554   | 25/633   | 21.8/554 |
| 36    | 21.8/554   | 29.8/759 | 21.8/554 |
| 36    | 23.6/600   | 25/633   | 23.6/600 |
| 48    | 28/710     | 29.8/759 | 28/710   |
| 60    | 28/710     | 33/843   | 28/710   |

Outdoor Unit Installation

**NOTE:** The minimum distance between the outdoor unit and walls described in the installation guide does not apply to airtight rooms. Be sure to keep the unit unobstructed in at least two of the three directions (M, N, P) (See Fig. 5.10)

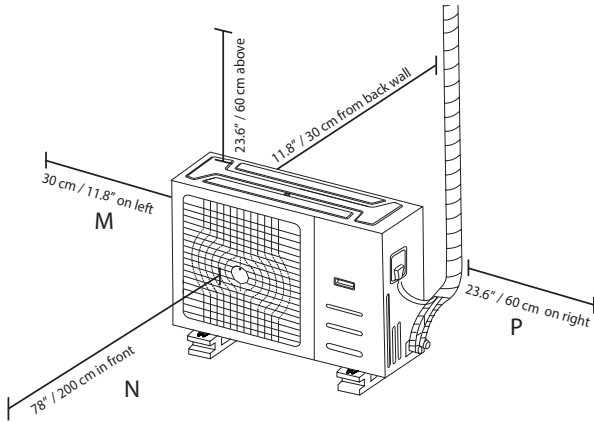

Fig. 5.10

2. Insert the drain joint into the hole in the base pan of the unit.
3. Rotate the drain joint 90° until it clicks in place facing the front of the unit.
4. Connect a drain hose extension (not included) to the drain joint to redirect water from the unit during heating mode.

If the drain joint doesn't come with a rubber seal (see Fig. 5.12 - B), do the following:

1. Insert the drain joint into the hole in the base pan of the unit. The drain joint will click in place.
2. Connect a drain hose extension (not included) to the drain joint to redirect water from the unit during heating mode.

**NOTE:** Make sure the water drains to a safe location where it will not cause water damage or a slipping hazard.

**Rows of series installation**

Table 5.3 The relations between H, A and L are as follows.

|       | L                    | A                     |
|-------|----------------------|-----------------------|
| L ≤ H | L ≤ 1/2H             | 9.8" / 25 cm or more  |
|       | 1/2H < L ≤ H         | 11.8" / 30 cm or more |
| L > H | Can not be installed |                       |

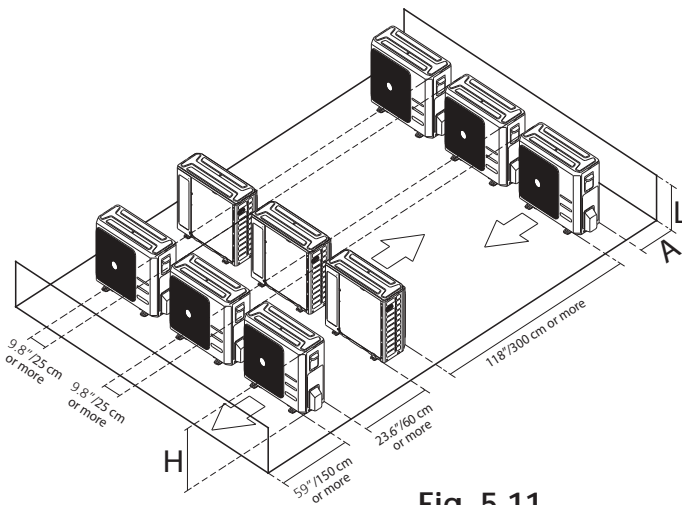

Fig. 5.11

**Drain Joint Installation**

If the drain joint comes with a rubber seal (see Fig. 5.12 - A), do the following:

1. Fit the rubber seal on the end of the drain joint that will connect to the outdoor unit.

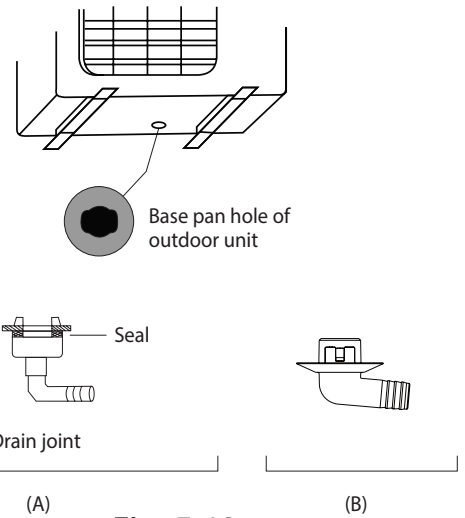

Fig. 5.12

**Notes On Drilling Hole In Wall**

You must drill a hole in the wall for the refrigerant piping, and the signal cable that will connect the indoor and outdoor units.

1. Determine the location of the wall hole based on the location of the outdoor unit.
2. Using a 2.5" (65-mm) core drill, drill a hole in the wall.

**NOTE:** When drilling the wall hole, make sure to avoid wires, plumbing, and other sensitive components.

3. Place the protective wall cuff in the hole. This protects the edges of the hole and will help seal it when you finish the installation process.

# Drainpipe Installation

# 6

The drainpipe is used to drain water away from the unit. Improper installation may cause unit and property damage.

## CAUTION

- Insulate all piping to prevent condensation, which could lead to water damage.
- If the drainpipe is bent or installed incorrectly, water may leak and cause a water-level switch malfunction.
- In HEAT mode, the outdoor unit will discharge water. Ensure that the drain hose is placed in an appropriate area to avoid water damage and slippage.
- **DO NOT** pull the drainpipe forcefully. This could disconnect it.

## NOTE ON PURCHASING PIPES

Installation requires a polyethylene tube (exterior diameter = 3.7-3.9cm, interior diameter = 3.2cm), which can be obtained at your local hardware store or dealer.

## Indoor Drainpipe Installation

Install the drainpipe as illustrated in Figure 6.2.

1. Cover the drainpipe with heat insulation to prevent condensation and leakage.
2. Attach the mouth of the drain hose to the unit's outlet pipe. Sheath the mouth of the hose and clip it firmly with a pipe clasp. (See Fig 6.1)

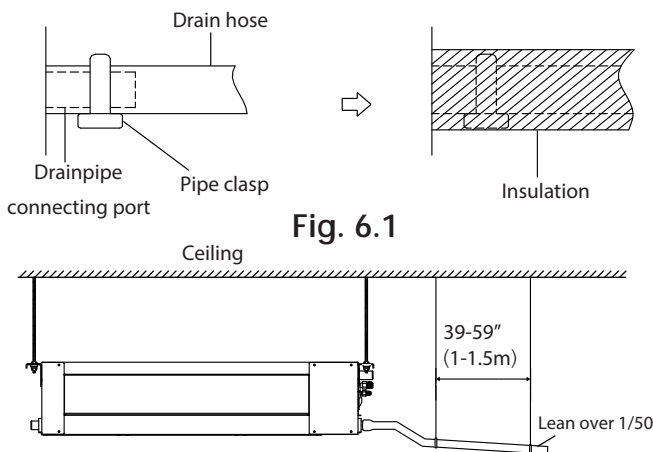

Fig. 6.1

Fig. 6.2

## NOTE ON DRAINPIPE INSTALLATION

- When using an extended drainpipe, tighten the indoor connection with an additional protection tube. This prevents it from pulling loose.
- The drainpipe should slope downward at a gradient of at least 1/100 to prevent water from flowing back into the air conditioner.
- To prevent the pipe from sagging, space hanging wires every 39-59" (1-1.5m).
- If the outlet of the drainpipe is higher than the body's pump joint, provide a lift pipe for the exhaust outlet of the indoor unit. The lift pipe must be installed no higher than 21.7" (55cm) from the ceiling board. the distance between the unit and the lift pipe must be less than 7.9" (20cm). Incorrect installation could cause water to flow back into the unit and flood.
- To prevent air bubbles, keep the drain hose level or slightly tiled up (< 3" / 75mm).

## Drainpipe installation for units with a pump

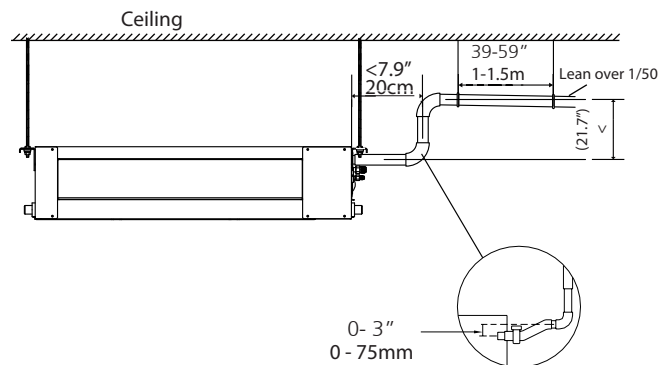

Fig. 6.3

**NOTE:** When connecting multiple drainpipes, install the pipes as illustrated in Fig 6.4.

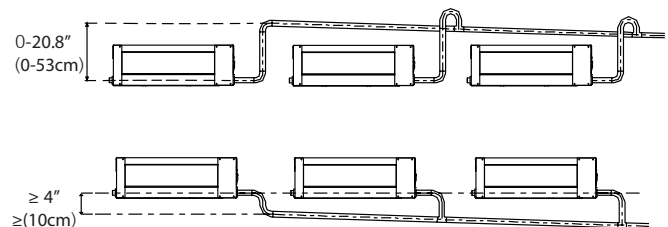

Fig. 6.4

- Using a 2.5" (65-mm) core drill, drill a hole in the wall. Make sure that the hole is drilled at a slight downward angle, so that the outdoor end of the hole is lower than the indoor end by about 0.5" (12mm). This will ensure proper water drainage (See Fig. 6.5). Place the protective wall cuff in the hole. This protects the edges of the hole and will help seal it once you finish installation.

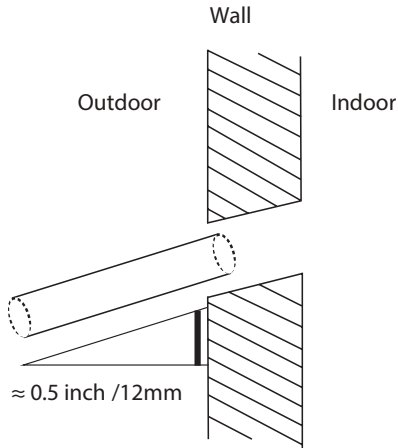

Fig. 6.5

**NOTE:** When drilling the hole, make sure to avoid wires, plumbing, and other sensitive components.

- Pass the drain hose through the wall hole. Make sure the water drains to a safe location where it will not cause water damage or a slipping hazard.

**NOTE:** The drainpipe outlet should be at least 1.9" (5cm) above the ground. If it touches the ground, the unit may become blocked and malfunction. If you discharge the water directly into a sewer, make sure that the drain has a U or S pipe to catch odors that might otherwise come back into the house.

### Drainage test

Check that the drainpipe is unhindered. This test should be performed on newly built houses before the ceiling is paved.

### Units without a pump.

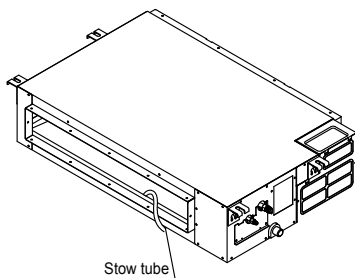

Fig.6.6

Fill the water pan with 2 liters of water. Check that the drainpipe is unhindered.

### Units with a pump.

- Remove the test cover.  
Fill the water pan with 2 liters of water.

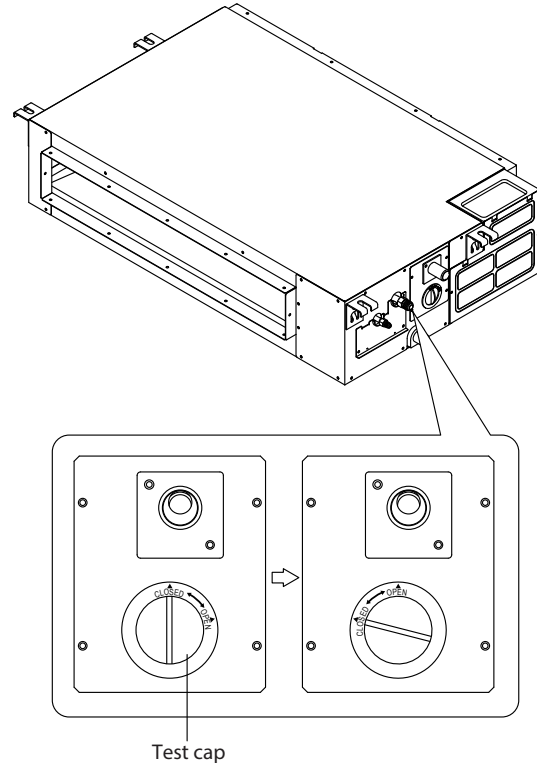

Fig.6.7

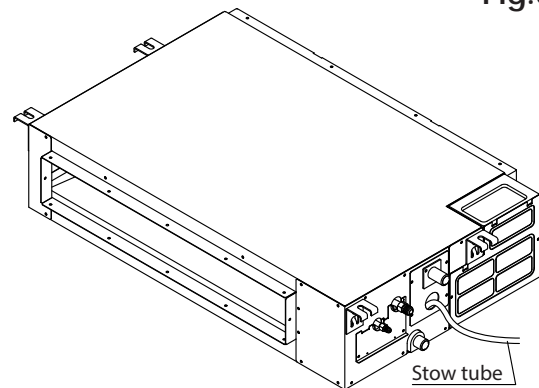

Fig.6.8

- Turn on the unit in COOLING mode. You will hear the drain pump. Check whether the water is discharged properly (a 1-minute lag is possible, depending on the length of the drain pipe), Check whether water leaks from the joints.
- Turn off the air conditioner and put the cap back on.

# Refrigerant Piping Connection

# 7

## Safety Precautions

### ⚠ WARNING

- All field piping must be completed by a licensed technician and must comply with the local and national regulations.
- When the air conditioner is installed in a small room, measures must be taken to prevent the refrigerant concentration in the room from exceeding the safety limit in the event of refrigerant leakage. If the refrigerant leaks and its concentration exceeds its proper limit, hazards due to lack of oxygen may result.
- When installing the refrigeration system, ensure that air, dust, moisture or foreign substances do not enter the refrigerant circuit. Contamination in the system may cause poor operating capacity, high pressure in the refrigeration cycle, explosion or injury.
- Ventilate the area immediately if there is refrigerant leakage during the installation. Leaked refrigerant gas is both toxic and flammable. Ensure there is no refrigerant leakage after completing the installation work.

## Notes On Pipe Length and Elevation

Ensure that the length of the refrigerant pipe, the number of bends, and the drop height between the indoor and outdoor units meets the requirements shown in Table 7.1:

**Table 7.1: The Maximum Length And Drop Height Based on Models. (Unit: ft/m.)**

| Type of model   | Capacity (Btu/h) | Length of piping | Maximum drop height |
|---|------------------|------------------|---------------------|
| North America, Australia and the eu frequency conversion Split Type | <15K             | 82/25            | 32.8/10             |
|   | ≥15K - <24K      | 98.4/30          | 65.6/20             |
|   | ≥24K - <36K      | 164/50           | 82/25               |
|   | ≥36K - ≤60K      | 213/65           | 98.4/30             |
| Other Split Type  | 12K              | 49/15            | 26/8                |
|   | 18K-24K          | 82/25            | 49/15               |
|   | 30K-36K          | 98.4/30          | 65.6/20             |
|   | 42K-60K          | 164/50           | 98.4/30             |

Refrigerant Piping Connection

## Refrigerant Piping with Twin Indoor Units

When installing multiple indoor units with a single outdoor unit, ensure that the length of the refrigerant pipe and the drop height between the indoor and outdoor units meet the requirements illustrated in the following diagram:

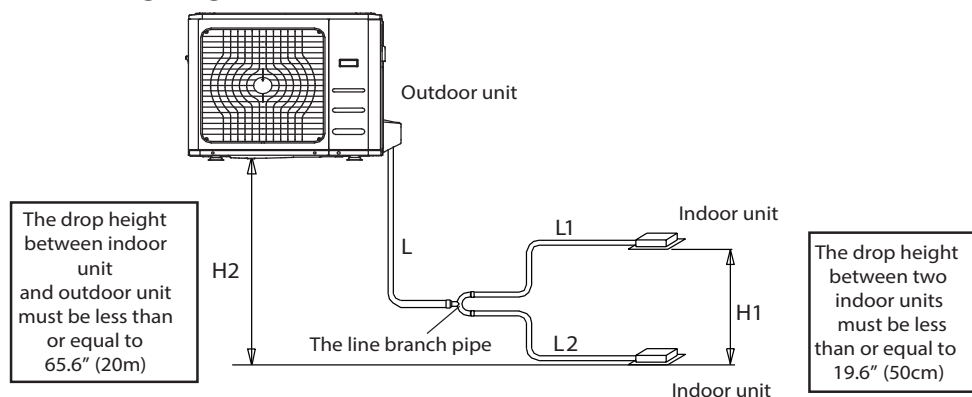

**Fig. 7.1**

Table 7.2

| Permitted length |   |           |          |                |
|------------------|---|-----------|----------|----------------|
| Piping length    | Total piping length                           | 18K+18K   | 98'/30m  | L+Max (L1, L2) |
|                  |   | 24K+24K   | 164'/50m |                |
|                  |   | 30K+30K   |          |                |
| Piping length    | (farthest distance from the line pipe branch) | 49'/15m   |          | L1, L2         |
|                  | (farthest distance from the line pipe branch) | 32.8'/10m |          | L1-L2          |
| Drop height      | Drop height between indoor and outdoor unit   | 65.6'/20m |          | H1             |
|                  | Drop height between two indoor units          | 1.6'/0.5m |          | H2             |

Size of joint pipes for indoor unit

Table 7.3 Size of joint pipes for 410A indoor unit

| Capacity of indoor unit (A) | Size of main pipe(mm) |              |                          |
|-----------------------------|-----------------------|--------------|--------------------------|
|                             | Gas side              | Liquid side  | Available branching pipe |
| 18K                         | Ø0.5"(12.7)           | Ø0.25"(6.35) | CE-FQZHN-01C             |
| 24K                         | Ø0.626"(15.9)         | Ø0.375"(9.5) | CE-FQZHN-01C             |
| 30K                         | Ø0.626"(15.9)         | Ø0.375"(9.5) | CE-FQZHN-01C             |

Size of joint pipes for outdoor unit

Base on the following tables, select the diameters of the outdoor unit connective pipes. In case of the main accessory pipe larger than the main pipe, take the larger one for the selection.

Table 7.4 Size of joint pipes for 410A outdoor unit

| Model | the size of main pipe(mm) |              |                        |
|-------|---------------------------|--------------|------------------------|
|       | Gas side                  | Liquid side  | The 1st branching pipe |
| 36K   | Ø0.626"(15.9)             | Ø0.375"(9.5) | CE-FQZHN-01C           |
| 48K   | Ø0.626"(15.9)             | Ø0.375"(9.5) | CE-FQZHN-01C           |
| 60K   | Ø0.626"(15.9)             | Ø0.375"(9.5) | CE-FQZHN-01C           |

Refrigerant Piping Connection Instructions

**! CAUTION**

- The branching pipe must be installed horizontally. An angle of more than 10° may cause malfunction.
- DO NOT** install the connecting pipe until both indoor and outdoor units have been installed.
- Insulate both the gas and liquid piping to prevent water leakage.

Step1: Cut pipes

When preparing refrigerant pipes, take extra care to cut and flare them properly. This will ensure efficient operation and minimize the need for future maintenance.

1. Measure the distance between the indoor and outdoor units.
2. Using a pipe cutter, cut the pipe a little longer than the measured distance.

**! CAUTION**

**DO NOT** deform pipe while cutting. Be extra careful not to damage, dent, or deform the pipe while cutting. This will drastically reduce the heating efficiency of the unit.

1. Make sure that the pipe is cut at a perfect 90° angle. Refer to Fig. 7.2 for examples of bad cuts

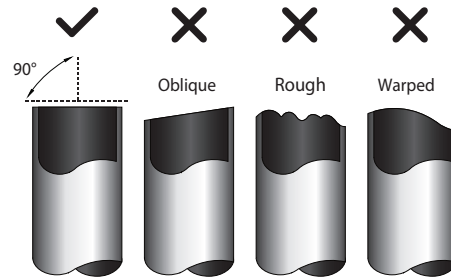

Fig. 7.2

Step2: Remove burrs.

Burrs can affect the air-tight seal of refrigerant piping connection. They must be completely removed.

1. Hold the pipe at a downward angle to prevent burrs from falling into the pipe.
2. Using a reamer or deburring tool, remove all burrs from the cut section of the pipe.

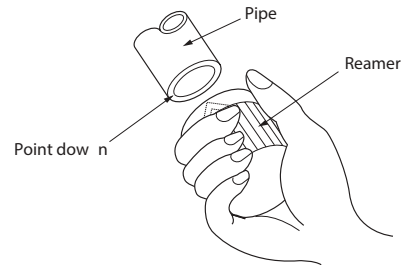

Fig. 7.3

Step 3: Flare pipe ends

Proper flaring is essential to achieve an airtight seal.

1. After removing burrs from cut pipe, seal the ends with PVC tape to prevent foreign materials from entering the pipe.
2. Sheath the pipe with insulating material.
3. Place flare nuts on both ends of pipe. Make sure they are facing in the right direction, because you can't put them on or change their direction after flaring. See Fig. 7.4

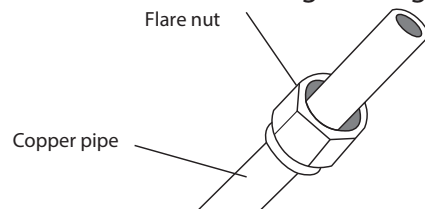

Fig. 7.4

4. Remove PVC tape from ends of pipe when ready to perform flaring work.

- Clamp flare form on the end of the pipe. The end of the pipe must extend beyond the flare form.

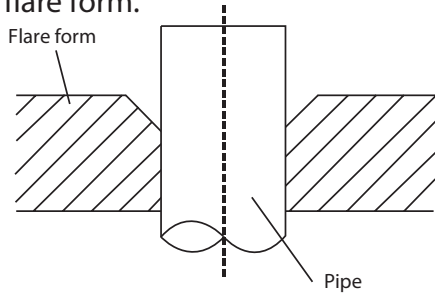

Fig. 7.5

- Place flaring tool onto the form.
- Turn the handle of the flaring tool clockwise until the pipe is fully flared. Flare the pipe in accordance with the dimensions shown in table 7.5.

Table 7.5: PIPING EXTENSION BEYOND FLARE FORM

| Pipe gauge | Tightening torque             | Flare dimension (A)<br>(Unit: Inch/mm) |           | Flare shape |
|------------|-------------------------------|--|-----------|-------------|
|            |                               | Min.                                   | Max.      |             |
| Ø 6.4      | 18-20 N.m<br>(183-204 kgf.cm) | 0.33/8.4                               | 0.34/8.7  |             |
| Ø 9.5      | 25-26 N.m<br>(255-265 kgf.cm) | 0.52/13.2                              | 0.53/13.5 |             |
| Ø 12.7     | 35-36 N.m<br>(357-367 kgf.cm) | 0.64/16.2                              | 0.65/16.5 |             |
| Ø 15.9     | 45-47 N.m<br>(459-480 kgf.cm) | 0.76/19.2                              | 0.78/19.7 |             |
| Ø 19.1     | 65-67 N.m<br>(663-683 kgf.cm) | 0.91/23.2                              | 0.93/23.7 |             |
| Ø 22       | 75-85 N.m<br>(765-867 kgf.cm) | 1.04/26.4                              | 1.06/26.9 |             |

Fig. 7.6

- Remove the flaring tool and flare form, then inspect the end of the pipe for cracks and even flaring.

#### Step 4: Connect pipes

Connect the copper pipes to the indoor unit first, then connect it to the outdoor unit. You should first connect the low-pressure pipe, then the high-pressure pipe.

- When connecting the flare nuts, apply a thin coat of refrigeration oil to the flared ends of the pipes.
- Align the center of the two pipes that you will connect.

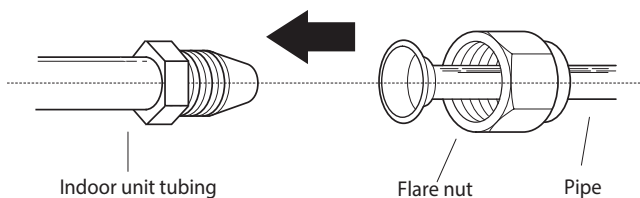

Fig. 7.7

- Tighten the flare nut as tightly as possible by hand.
- Using a spanner, grip the nut on the unit tubing.
- While firmly gripping the nut, use a torque wrench to tighten the flare nut according to the torque values in table 7.5.

**NOTE:** Use both a spanner and a torque wrench when connecting or disconnecting pipes to/from the unit.

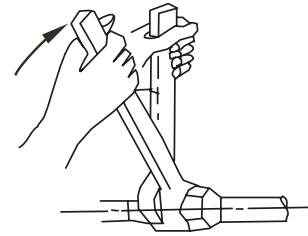

Fig. 7.8

#### ! CAUTION

- Ensure to wrap insulation around the piping. Direct contact with the bare piping may result in burns or frostbite.
- Make sure the pipe is properly connected. Over tightening may damage the bell mouth and under tightening may lead to leakage.

#### NOTE ON MINIMUM BEND RADIUS

Carefully bend the tubing in the middle according to the diagram below. **DO NOT** bend the tubing more than 90° or more than 3 times.

Bend the pipe with thumb

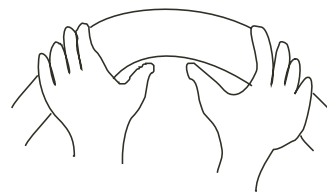

min-radius 3.9" (10cm)

Fig. 7.9

- After connecting the copper pipes to the indoor unit, wrap the power cable, signal cable and the piping together with binding tape.

**NOTE:** **DO NOT** intertwine signal cable with other wires. While bundling these items together, do not intertwine or cross the signal cable with any other wiring.

- Thread this pipeline through the wall and connect it to the outdoor unit.
- Insulate all the piping, including the valves of the outdoor unit.
- Open the stop valves of the outdoor unit to start the flow of the refrigerant between the indoor and outdoor unit.

#### ! CAUTION

Check to make sure there is no refrigerant leak after completing the installation work. If there is a refrigerant leak, ventilate the area immediately and evacuate the system (refer to the Air Evacuation section of this manual).

## Safety Precautions

### **WARNING**

- Disconnect the power supply before working on the unit.
- All wiring must be performed according to local and national regulations.
- Wiring must be done by a qualified technician. Improper connections may cause electrical malfunction, injury, or fire.
- An independent circuit and single outlet must be used for this unit.  
**DO NOT** plug another appliance or charger into the same outlet. If the cannot handle the load or there is a defect in the wiring, it can lead to shock, fire, and unit and property damage.
- Connect the power cable to the terminals and fasten it with a clamp. An insecure connection may cause fire.
- Make sure that all wiring is done correctly and the control board cover is properly installed. Failure to do so can cause overheating at the connection points, fire, and electrical shock.
- Ensure that main power supply connection is made through a switch that disconnects all poles, with contact gap of at least 0.118" (3mm).
- **DO NOT** modify the length of the power cord or use an extension cord.

### **CAUTION**

- Connect the outdoor wires before connecting the indoor wires.
- Make sure you ground the unit. The grounding wire should be located away from gas pipes, water pipes, lightning rods, telephone wires or other grounding wires. Improper grounding may cause electrical shock.
- **DO NOT** connect the unit to the power source until all wiring and piping is completed.
- Make sure that you do not cross your electrical wiring with your signal wiring. This may cause distortion and interference.

To prevent distortion when the compressor starts (you can find the unit's power information on the rating sticker):

- The unit must be connected to the main outlet. Normally, the power supply must have a impedance of 32 ohms.
- No other equipment should be connected to the same power circuit.

### TAKE NOTE OF FUSE SPECIFICATIONS

The air conditioner's printed circuit board (PCB) is designed with a fuse that provides overcurrent protection. The specifications of the fuse are printed on the circuit board, examples of such are T5A/250VAC and T10A/250VAC.

## Outdoor Unit Wiring

### **WARNING**

Before performing any electrical or wiring work, turn off the main power to the system.

1. Prepare the cable for connection
  - a. You must first choose the right cable size. Be sure to use H07RN-F cables.

**Table 8.1: Minimum Cross-Sectional Area of Power and Signal Cables in North America**

| Rated Current of Appliance (A) | AWG |
|--------------------------------|-----|
| ≤7                             | 18  |
| 7 - 13                         | 16  |
| 13 - 18                        | 14  |
| 18 - 25                        | 12  |
| 25 - 30                        | 10  |

**Table 8.2: Other World Regions**

| Rated Current of Appliance (A) | Nominal Cross-Sectional Area (mm <sup>2</sup> ) |
|--------------------------------|---|
| ≤ 6                            | 0.75  |
| 6 - 10                         | 1   |
| 10 - 16                        | 1.5   |
| 16 - 25                        | 2.5   |
| 25- 32                         | 4   |
| 32 - 45                        | 6   |

- b. Using wire strippers, strip the rubber jacket from both ends of the signal cable to reveal approximately 5.9" (15cm) of wire.
- c. Strip the insulation from the ends.
- d. Using a wire crimper, crimp u-lugs on the ends.

**NOTE:** When connecting the wires, strictly follow the wiring diagram found inside the electrical box cover.

2. Remove the electric cover of the outdoor unit. If there is no cover on the outdoor unit, take off the bolts from the maintenance board and remove the protection board. (See Fig. 8.1, 8.2)

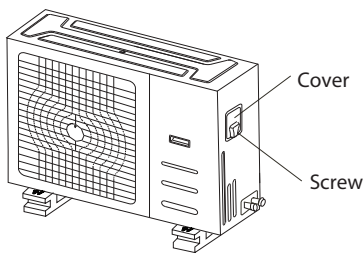

**Fig. 8.1**

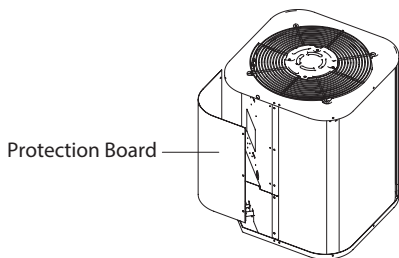
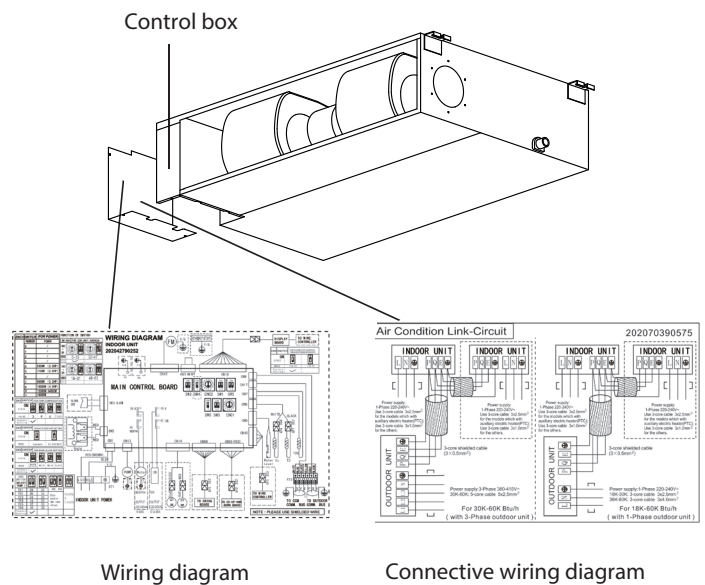

**Fig. 8.2**

3. Connect the u-lugs to the terminals. Match the wire colors/labels with the labels on the terminal block, Firmly screw the u-lug of each wire to its corresponding terminal.
4. Clamp down the cable with the cable clamp.
5. Insulate unused wires with electrical tape. Keep them away from any electrical or metal parts.
6. Reinstall the cover of the electric control box.

## Indoor Unit Wiring

1. Prepare the cable for connection
  - a. Using wire strippers, strip the rubber jacket from both ends of the signal cable to reveal about 5.9" (15cm) of the wire.
  - b. Strip the insulation from the ends of the wires.
  - c. Using a wire crimper, crimp the u-lugs to the ends of the wires.
2. Remove the cover of the electric control box on your indoor unit.
3. Connect the u-lugs to the terminals. Match the wire colors/labels with the labels on the terminal block, Firmly screw the u-lug of each wire to its corresponding terminal. Refer to the Serial Number and Wiring Diagram located on the cover of the electric control box.



**Fig. 8.3**

Magnetic ring(if supplied and packed with the accessories)

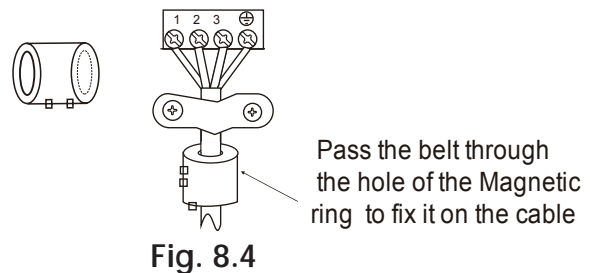

**Fig. 8.4**

## ! CAUTION

- While connecting the wires, please strictly follow the wiring diagram.
- The refrigerant circuit can become very hot. Keep the interconnection cable away from the copper tube.

4. Clamp down the cable with the cable clamp. The cable must not be loose or pull on the u-lugs.
5. Reattach the electric box cover.

### Using the wire control to set external static pressure (some models)

- You can use the unit's automatic airflow adjustment function to set external static pressure.
  - Automatic airflow adjustment is the volume of blow-off air that has been automatically adjusted to the quantity rated.
1. Make sure the test run is done with a dry coil. If the coil is not dry, run the unit for 2 hours in FAN ONLY mode to dry the coil.
  2. Check that both power supply wiring and duct installation have been completed. Check that any closing dampers are open. Check that the air filter is properly attached to the air suction side passage of the unit.
  3. If there is more than one air inlet and outlet, adjust the dampers so that the airflow rate of each air inlet and outlet conforms with the designed airflow rate. Make sure the unit is in FAN ONLY mode. Press and set the airflow adjustment button on the remote control to change the airflow rate from H or L.
  4. Set the parameters for automatic airflow adjustment. When the air conditioning unit is off, perform the following steps:
    - Press "COPY".
    - Press "+" or "-" to select the AF.

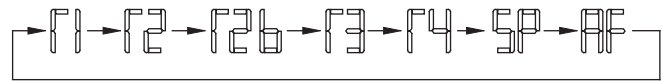

- Press "CONFIRM". The air conditioning unit will then start the fan for airflow automatic adjustment.

ON will flash during when the fan is on during automatic airflow adjustment.

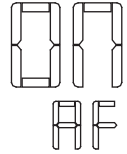

## ! CAUTION

- **DO NOT** adjust the dampers when automatic airflow adjustment is active.

After 3 to 6 minutes, the air conditioning unit stops operating once automatic airflow adjustment has finished.

## ! CAUTION

- If there is no change after airflow adjustment in the ventilation paths, be sure to reset automatic airflow adjustment.
- If there is no change to ventilation paths after airflow adjustment, contact your dealer, especially if this occurs after testing the outdoor unit or if the unit has been moved to a different location.
- Do not use automatic airflow adjustment with remote control, if you are using booster fans, outdoor air processing unit, or a HRV via duct.
- If the ventilation paths have been changed, reset airflow automatic adjustment as described from step 3 onwards.

## Power Specifications

**NOTE:** Electric auxiliary heating type circuit breaker/fuse need to add more than 10 A.

### Indoor Power Supply Specifications

| MODEL(Btu/h)             |                    | ≤18K     | 19K~24K  | 25K~36K  | 37K~48K  | 49K~60K  |
|--------------------------|--------------------|----------|----------|----------|----------|----------|
| POWER                    | PHASE              | 1 Phase  | 1 Phase  | 1 Phase  | 1 Phase  | 1 Phase  |
|                          | FREQUENCY AND VOLT | 208-240V | 208-240V | 208-240V | 208-240V | 208-240V |
| CIRCUIT BREAKER/ FUSE(A) |                    | 25/20    | 32/25    | 50/40    | 70/55    | 70/60    |

| MODEL(Btu/h)            |                    | ≤36K     | 37K~60K  | ≤36K     | 37K~60K  |
|-------------------------|--------------------|----------|----------|----------|----------|
| POWER                   | PHASE              | 3 Phase  | 3 Phase  | 3 Phase  | 3 Phase  |
|                         | FREQUENCY AND VOLT | 380-420V | 380-420V | 208-240V | 208-240V |
| CIRCUIT BREAKER/FUSE(A) |                    | 25/20    | 32/25    | 32/25    | 45/35    |

### Outdoor Power Supply Specifications

| MODEL(Btu/h)             |                    | ≤18K     | 19K~24K  | 25K~36K  | 37K~48K  | 49K~60K  |
|--------------------------|--------------------|----------|----------|----------|----------|----------|
| POWER                    | PHASE              | 1 Phase  | 1 Phase  | 1 Phase  | 1 Phase  | 1 Phase  |
|                          | FREQUENCY AND VOLT | 208-240V | 208-240V | 208-240V | 208-240V | 208-240V |
| CIRCUIT BREAKER/ FUSE(A) |                    | 25/20    | 32/25    | 50/40    | 70/55    | 70/60    |

| MODEL(Btu/h)            |                    | ≤36K     | 37K~60K  | ≤36K     | 37K~60K  |
|-------------------------|--------------------|----------|----------|----------|----------|
| POWER                   | PHASE              | 3 Phase  | 3 Phase  | 3 Phase  | 3 Phase  |
|                         | FREQUENCY AND VOLT | 380-420V | 380-420V | 208-240V | 208-240V |
| CIRCUIT BREAKER/FUSE(A) |                    | 25/20    | 32/25    | 32/25    | 45/35    |

### Independent Power Supply Specifications

| MODEL(Btu/h)             |                    | ≤18K     | 19K~24K  | 25K~36K  | 37K~48K  | 49K~60K  |
|--------------------------|--------------------|----------|----------|----------|----------|----------|
| POWER (indoor)           | PHASE              | 1 Phase  | 1 Phase  | 1 Phase  | 1 Phase  | 1 Phase  |
|                          | FREQUENCY AND VOLT | 208-240V | 208-240V | 208-240V | 208-240V | 208-240V |
| CIRCUIT BREAKER/ FUSE(A) |                    | 15/10    | 15/10    | 15/10    | 15/10    | 15/10    |
| POWER (outdoor)          | PHASE              | 1 Phase  | 1 Phase  | 1 Phase  | 1 Phase  | 1 Phase  |
|                          | FREQUENCY AND VOLT | 208-240V | 208-240V | 208-240V | 208-240V | 208-240V |
| CIRCUIT BREAKER/ FUSE(A) |                    | 25/20    | 32/25    | 50/40    | 70/55    | 70/60    |

| MODEL(Btu/h)            |                    | ≤36K     | 37K~60K  | ≤36K     | 37K~60K  |
|-------------------------|--------------------|----------|----------|----------|----------|
| POWER (indoor)          | PHASE              | 1 Phase  | 1 Phase  | 1 Phase  | 1 Phase  |
|                         | FREQUENCY AND VOLT | 208-240V | 208-240V | 208-240V | 208-240V |
| CIRCUIT BREAKER/FUSE(A) |                    | 15/10    | 15/10    | 15/10    | 15/10    |
| POWER (outdoor)         | PHASE              | 3 Phase  | 3 Phase  | 3 Phase  | 3 Phase  |
|                         | FREQUENCY AND VOLT | 380-420V | 380-420V | 208-240V | 208-240V |
| CIRCUIT BREAKER/FUSE(A) |                    | 25/20    | 32/25    | 32/25    | 45/35    |

### Inverter Type A/C Power Specifications

| MODEL(Btu/h)            |                    | ≤18K     | 19K~24K  | 25K~36K  | 37K~48K  | 49K~60K  |
|-------------------------|--------------------|----------|----------|----------|----------|----------|
| POWER (indoor)          | PHASE              | 1 Phase  | 1 Phase  | 1 Phase  | 1 Phase  | 1 Phase  |
|                         | FREQUENCY AND VOLT | 220-240V | 220-240V | 220-240V | 220-240V | 220-240V |
| CIRCUIT BREAKER/FUSE(A) |                    | 15/10    | 15/10    | 15/10    | 15/10    | 15/10    |
| POWER (outdoor)         | PHASE              | 1 Phase  | 1 Phase  | 1 Phase  | 1 Phase  | 1 Phase  |
|                         | FREQUENCY AND VOLT | 208-240V | 208-240V | 208-240V | 208-240V | 208-240V |
| CIRCUIT BREAKER/FUSE(A) |                    | 25/20    | 25/20    | 40/30    | 50/40    | 50/40    |

| MODEL(Btu/h)            |                    | ≤36K     | 37K~60K  | ≤36K     | 37K~60K  |
|-------------------------|--------------------|----------|----------|----------|----------|
| POWER (indoor)          | PHASE              | 1 Phase  | 1 Phase  | 1 Phase  | 1 Phase  |
|                         | FREQUENCY AND VOLT | 220-240V | 220-240V | 220-240V | 220-240V |
| CIRCUIT BREAKER/FUSE(A) |                    | 15/10    | 15/10    | 15/10    | 15/10    |
| POWER (outdoor)         | PHASE              | 3 Phase  | 3 Phase  | 3 Phase  | 3 Phase  |
|                         | FREQUENCY AND VOLT | 380-420V | 380-420V | 208-240V | 208-240V |
| CIRCUIT BREAKER/FUSE(A) |                    | 25/20    | 32/25    | 32/25    | 40/30    |

## Safety Precautions

### ! CAUTION

- Use a vacuum pump with a gauge reading lower than  $-0.1\text{MPa}$  and an air discharge capacity above  $40\text{L}/\text{min}$ .
- The outdoor unit does not need to be vacuumed. **DO NOT** open the outdoor unit's gas and liquid stop valves.
- Ensure that the Compound Meter reads  $-0.1\text{MPa}$  or below after 2 hours. If after three hours the gauge reading is still above  $-0.1\text{MPa}$ , check if there is a gas leak or water inside the pipe. If there is no leak, perform another evacuation for 1 or 2 hours.
- **DO NOT** use refrigerant gas to evacuate the system.

## Evacuation Instructions

Before using a manifold gauge and a vacuum pump, read their operation manuals to make sure you know how to use them properly.

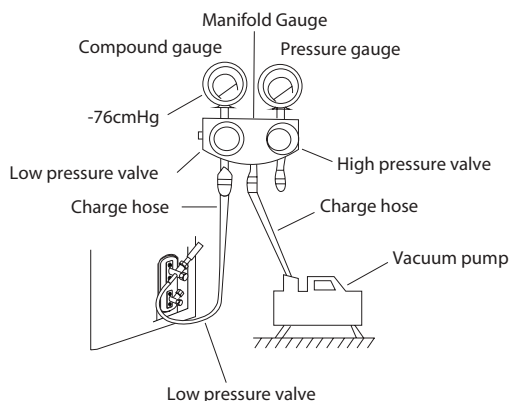

Fig. 9.1

1. Connect the manifold gauge's charge hose to the service port on the outdoor unit's low pressure valve.
2. Connect the manifold gauge's charge hose from the to the vacuum pump.
3. Open the Low Pressure side of the manifold gauge. Keep the High Pressure side closed.

4. Turn on the vacuum pump to evacuate the system.
5. Run the vacuum for at least 15 minutes, or until the Compound Meter reads  $-76\text{cmHG}$  ( $-1 \times 10^5\text{Pa}$ ).
6. Close the manifold gauge's Low Pressure valve and turn off the vacuum pump.
7. Wait for 5 minutes, then check that there has been no change in system pressure.

**NOTE:** If there is no change in system pressure, unscrew the cap from the packed valve (high pressure valve). If there is a change in system pressure, there may be a gas leak.

8. Insert hexagonal wrench into the packed valve (high pressure valve) and open the valve by turning the wrench  $1/4$  counterclockwise. Listen for gas to exit the system, then close the valve after 5 seconds.

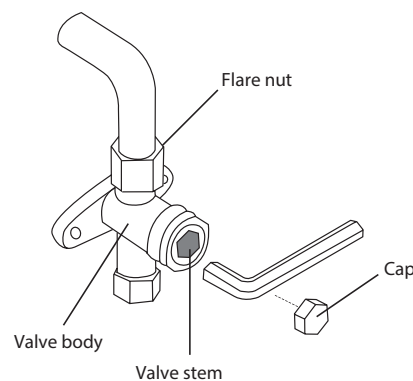

Fig. 9.2

9. Watch the Pressure Gauge for one minute to make sure that there is no change in pressure. It should read slightly higher than the atmospheric pressure.
10. Remove the charge hose from the service port.
11. Using hexagonal wrench, fully open both the high pressure and low pressure valves.

### OPEN VALVE STEMS GENTLY

When opening the valve stems, turn the hexagonal wrench until it hits against the stopper. **DO NOT** try to force the valve to open further.

12. Tighten valve caps by hand, then tighten it using the proper tool.

## Note On Adding Refrigerant

### ! CAUTION

- Refrigerant charging must be performed after wiring, vacuuming, and the leak testing.
- **DO NOT** exceed the maximum allowable quantity of refrigerant or overcharge the system. Doing so can damage the unit or impact it's functioning.
- Charging with unsuitable substances may cause explosions or accidents. Ensure that the appropriate refrigerant is used.
- Refrigerant containers must be opened slowly. Always use protective gear when charging the system.
- **DO NOT** mix refrigerants types.

Some systems require additional charging depending on pipe lengths. The standard pipe length varies according to local regulations. For example, in North America, the standard pipe length is 7.5m (25') In other areas, the standard pipe length is 5m (16'). The additional refrigerant to be charged can be calculated using the following formula:

#### Liquid Side Diameter

|   | φ6.35(1/4")   | φ9.52(3/8")  | φ12.7(1/2")   |
|---|---|--|---|
| R22<br>(orifice tube in the indoor unit):     | (Total pipe length - standard pipe length) x 30g (0.32oz)/m(ft) | (Total pipe length - standard pipe length) x 65g(0.69oz)/m(ft) | (Total pipe length - standard pipe length) x 115g(1.23oz)/m(ft) |
| R22<br>(orifice tube in the outdoor unit):    | (Total pipe length - standard pipe length) x 15g(0.16oz)/m(ft)  | (Total pipe length - standard pipe length) x 30(0.32oz)/m(ft)  | (Total pipe length - standard pipe length) x 60g(0.64oz)/m(ft)  |
| R410A:<br>(orifice tube in the indoor unit):  | (Total pipe length - standard pipe length) x 30g(0.32oz)/m(ft)  | (Total pipe length - standard pipe length) x 65g(0.69oz)/m(ft) | (Total pipe length - standard pipe length) x 115g(1.23oz)/m(ft) |
| R410A:<br>(orifice tube in the outdoor unit): | (Total pipe length - standard pipe length) x 15g(0.16oz)/m(ft)  | (Total pipe length - standard pipe length) x 30g(0.32oz)/m(ft) | (Total pipe length - standard pipe length) x 65g(0.69oz)/m(ft)  |

## Test Run

### Before Test Run

A test run must be performed after the entire system has been completely installed. Confirm the following points before performing the test:

- a) Indoor and outdoor units are properly installed.
- b) Piping and wiring are properly connected.
- c) No obstacles near the inlet and outlet of the unit that might cause poor performance or product malfunction.
- d) Refrigeration system does not leak.
- e) Drainage system is unimpeded and draining to a safe location.
- f) Heating insulation is properly installed.
- g) Grounding wires are properly connected.
- h) Length of the piping and additional refrigerant stow capacity have been recorded.
- i) Power voltage is the correct voltage for the air conditioner.

### ! CAUTION

Failure to perform the test run may result in unit damage, property damage or personal injury.

### Test Run Instructions

1. Open both the liquid and gas stop valves.
2. Turn on the main power switch and allow the unit to warm up.
3. Set the air conditioner to COOL mode.
4. For the Indoor Unit
  - a. Ensure the remote control and its buttons work properly.
  - b. Ensure the louvers move properly and can be changed using the remote control.
  - c. Double check to see if the room temperature is registered correctly.
  - d. Ensure the indicators on the remote control and the display panel on the indoor unit work properly.
  - e. Ensure the manual buttons on the indoor unit works properly.

- f. Check to see that the drainage system is unimpeded and draining smoothly.
  - g. Ensure there is no vibration or abnormal noise during operation.
5. For the Outdoor Unit
    - a. Check to see if the refrigeration system is leaking.
    - b. Make sure there is no vibration or abnormal noise during operation.
    - c. Ensure the wind, noise, and water generated by the unit do not disturb your neighbors or pose a safety hazard.
  6. Drainage Test
    - a. Ensure the drainpipe flows smoothly. New buildings should perform this test before finishing the ceiling.
    - b. Remove the test cover. Add 2,000ml of water to the tank through the attached tube.
    - c. Turn on the main power switch and run the air conditioner in COOL mode.
    - d. Listen to the sound of the drain pump to see if it makes any unusual noises.
    - e. Check to see that the water is discharged. It may take up to one minute before the unit begins to drain depending on the drainpipe.
    - f. Make sure that there are no leaks in any of the piping.
    - g. Stop the air conditioner. Turn off the main power switch and reinstall the test cover.

**NOTE:** If the unit malfunctions or does not operate according to your expectations, please refer to the Troubleshooting section of the Owner's Manual before calling customer service.