

AUXILIARY HEATER

Installation Manual

Safety precautions & Installation

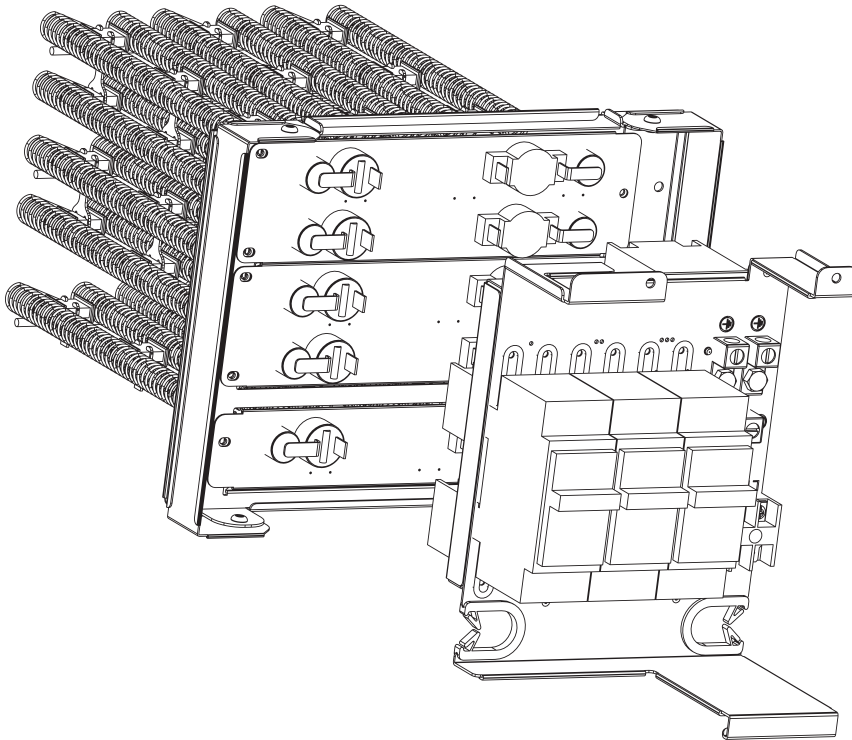

Models:

CH-PQEH05KW
CH-PQEH10KW
CH-PQEH15KW
CH-PQEH20KW

IMPORTANT NOTE:



Read this manual carefully before installing or operating your new air conditioning unit. Make sure to save this manual for future reference.





About the Company

With more than 25 years of experience in air conditioning and ventilation, **Cooper&Hunter** is considered one of the HVAC leaders in the US market. Distributed in more than 55 countries worldwide, the brand is dedicated to technological innovation and consumer-driven product development, while generating HVAC equipment that adheres to the highest quality standards in the US. Our focus is to provide reliable, energy-efficient, and cost-effective residential and commercial air conditioning solutions.

Learn more about your unit

Learn more technical information about your unit at www.cooperandhunter.us, where you can find submittals, leaflets, videos and all technical specifications of your unit.

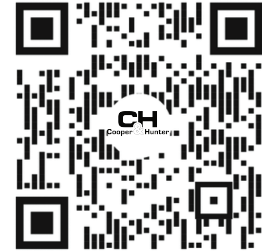
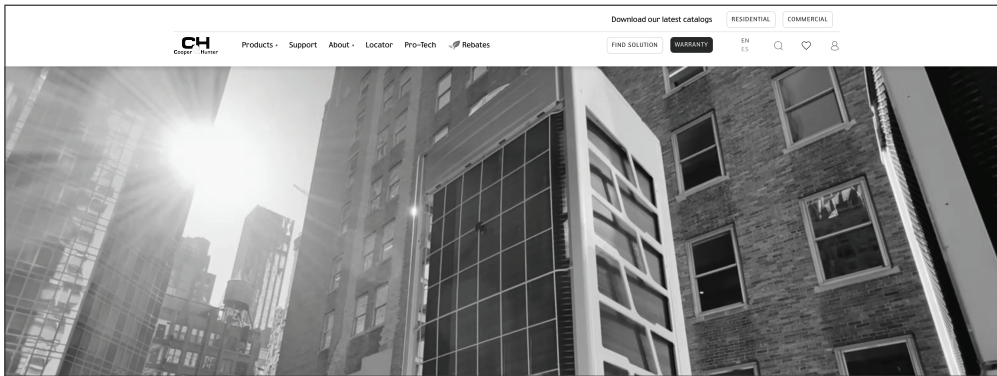

Step 1

On the website cooperandhunter.us, type in your unit model number into the search field and click enter.

Step 2

Make sure the unit that appears in your search results matches your unit and click on it for more details.

Step 3

On the detail page of your unit you will be able to view the technical specifications, description and additional documents, such as Submittals, Leaflets and Videos about your unit.

Warranty registration

It is important to register your unit's warranty. This will provide more security and agility whenever you need to request technical support from **Cooper&Hunter**.

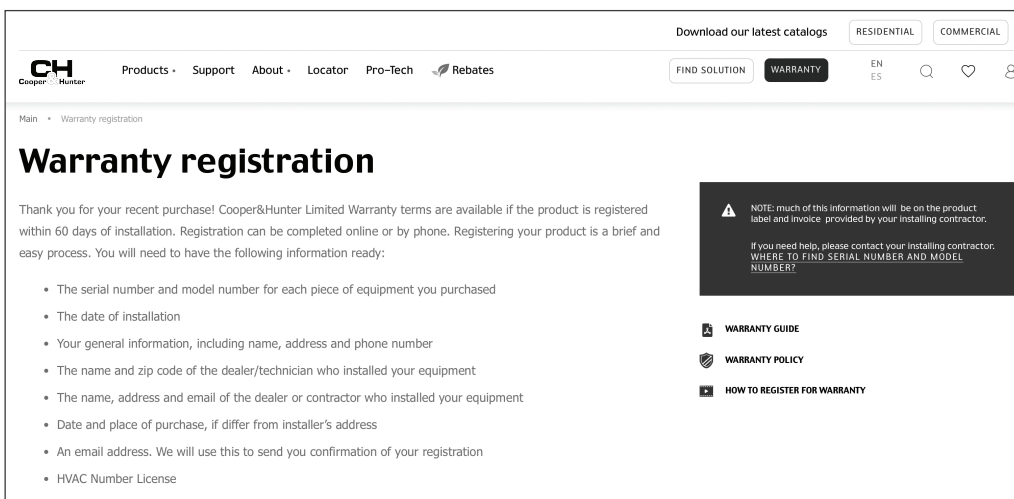

Step 1

Visit the warranty registration page at cooperandhunter.us/warranty and follow the steps to register a new unit. For more information on the warranty terms and policies, see pages at the end of your user manual.

Step 2

Complete the entire warranty registration form, including the information of the licensed technician who installed your equipment. Once complete, you will receive a confirmation email stating your application to register your unit has been submitted.

How to apply for the rebate program

Almost all Cooper&Hunter equipment is eligible for the rebate program. Visit our website to see if the rebates apply to your location.

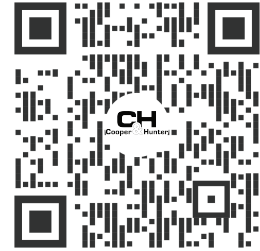
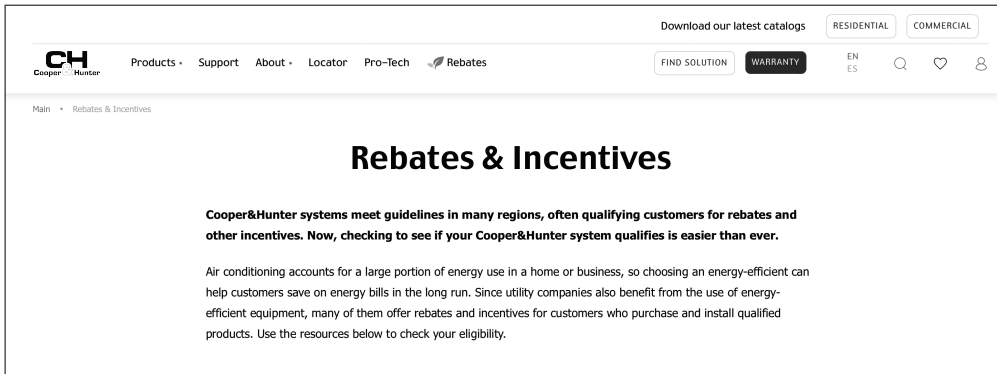

Step 1

Go to cooperandhunter.us/rebates to add your zip code and select your outdoor unit to see if your unit qualifies for the rebate.

Step 2

See the list of available rebates and instructions on how to apply for each available rebate.

Our Commitment to Innovation and Efficiency

At Cooper&Hunter, innovation is at the heart of everything we do. We continuously invest in research and development to bring you the most advanced, reliable, and energy-efficient HVAC solutions. Our goal is to lead the industry in environmental and energy efficiency, and we will spare no effort to achieve this.

We are proud to offer products that, not only meet, but exceed the highest quality standards. Our dedication to technological innovation ensures that you receive the best possible performance and value from your HVAC systems.

Explore more

For more information, including tutorials and updates, visit our official YouTube channel, Instagram and Facebook page. Simply search our social media to access a variety of helpful videos and guides.



 YouTube
[@CooperandHunterusa](https://www.youtube.com/@CooperandHunterusa)



 Instagram
[@cooperandhunterusa](https://www.instagram.com/cooperandhunterusa)



 Facebook
[Cooper&Hunter USA](https://www.facebook.com/Cooper&HunterUSA)

Remember to **subscribe** to stay up-to-date with the latest content!

INSTALLATION MANUAL

SAFETY PRECAUTIONS	02
INSTALLATION	04
ELECTRICAL SPECIFICATIONS	07

Read this manual

Inside you'll find many helpful hints on how to use and maintain your auxiliary heater properly. Just a little preventive care on your part can save you a great deal of time and money over the life of your auxiliary heater. These instructions may not cover every possible condition of use, so common sense and attention to safety is required when installing, operating and maintaining this product.

SAFETY PRECAUTIONS

Intended Use

The following safety guidelines are intended to prevent unforeseen risks or damage from unsafe or incorrect operation of the appliance. Please check the packaging and appliance on arrival to make sure everything is intact to ensure safe operation. If you find any damage, please contact the retailer or dealer. Please note modifications or alterations to the appliance are not allowed for your safety. Unintended use may cause hazards and loss of warranty claims.

Explanation of Symbols



WARNING

The signal word indicates a hazard with a medium level of risk which, if not avoided, may result in death or serious injury.



CAUTION

The signal word indicates a hazard with a low degree of risk which, if not avoided, may result in minor or moderate injury.

Read these operating instructions carefully and attentively before using/commissioning the unit and keep them in the immediate vicinity of the installation site or unit for later use!

WARNING

This appliance is not intended for use by persons (including children) with reduced physical, sensory or mental capabilities, or lack of experience and knowledge, unless they have been given supervision or instruction concerning use of the appliance by a person responsible for their safety. Children should be supervised to ensure that they do not play with the appliance.

ELECTRICAL WARNINGS

- The product must be properly grounded at the time of installation, or electrical shock may occur.
- For all electrical work, follow all local and national wiring standards, regulations, and the Installation Manual. Connect cables tightly, and clamp them securely to prevent external forces from damaging the terminal. Improper electrical connections can overheat and cause fire, and may also cause shock. All electrical connections must be made according to the Electrical Connection Diagram located on the panels of the indoor and outdoor units.
- All wiring must be properly arranged to ensure that the control board cover can close properly. If the control board cover is not closed properly, it can lead to corrosion and cause the connection points on the terminal to heat up, catch fire, or cause electrical shock.
- If connecting power to fixed wiring, an all-pole disconnection device must be incorporated in the fixed wiring in accordance with the wiring rules.

WARNINGS FOR PRODUCT INSTALLATION

- Installation must be performed by an authorized dealer or specialist. Defective installation can cause water leakage, electrical shock, or fire.
- Installation must be performed according to the installation instructions. Improper installation can cause water leakage, electrical shock, or fire. (In North America, installation must be performed in accordance with the requirement of NEC and CEC by authorized personnel only.)
- Contact an authorized service provider for repair or maintenance of this unit. This appliance shall be installed in accordance with national wiring regulations.
- Only use the included accessories, parts, and specified parts for installation. Using non-standard parts can cause water leakage, electrical shock, fire, and can cause the unit to fail.
- For units that have an auxiliary electric heater, do not install the unit within 1 meter (3 feet) of any combustible materials.
- **Do not** install the unit in a location that may be exposed to combustible gas leaks. If combustible gas accumulates around the unit, it may cause fire.
- Do not turn on the power until all work has been completed.
- When moving or relocating the auxiliary heater, consult experienced service technicians for disconnection and reinstallation of the unit.
How to install the appliance to its support, please read the information for details in indoor unit.

WARNINGS FOR CLEANING AND MAINTENANCE





- Turn off the device and disconnect the power before cleaning. Failure to do so can cause electrical shock.

INSTALLATION

NOTICE

Installation must be performed by a licensed contractor. Please make necessary precaution when performing the installation operation.

Accessories

Name of Accessories	Q'ty(pc)	Shape
Manual	1	
Foam gasket	1	
Packaged screws	1	
Silicone breaker cover	1	
Electric auxiliary heating wiring diagram	1	
Circuit breaker label	1	

Model size selection

For installations requiring supplemental heating, the optional Electric Auxiliary Heat Module is available in sizes from 5kW to 20kW to accommodate appropriate sizing given the specific heat load and electrical requirements of each installation. Please refer to the table below for selection of available sizes of each outdoor unit model, being sure to avoid improper matching.

OUTDOOR UNIT MODEL (Btu/h)	5kW	10kW	15kW	20kW
18K	Y	Y	-	-
24K	Y	Y	Y	-
30K	Y	Y	Y	-
36K	Y	Y	Y	Y
48K	-	Y	Y	Y
60K	-	Y	Y	Y

NOTICE

Only use matched modules certified for use with model. Please refer to the Electric Auxiliary Heat Model specification for additional details to ensure proper selection and installation.

Preparations for Installation

Before installation, please confirm the electric auxiliary heat module and supplied accessories are complete and free of any damage. Do not attempt to install if damage is present.

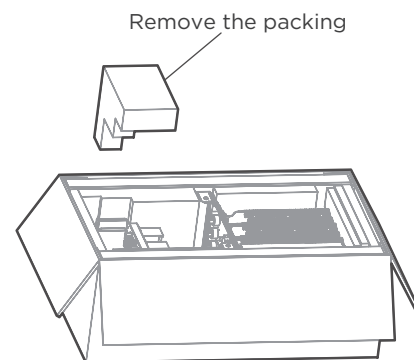

Hold the two parts together and take them out from box.

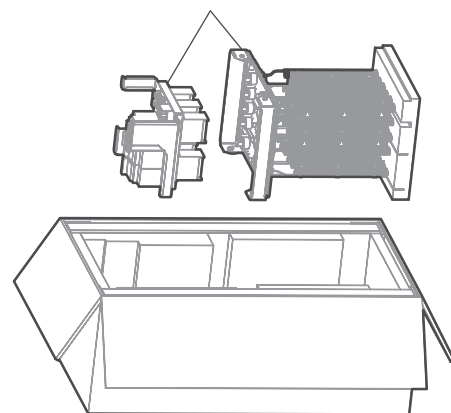

Remove the packing

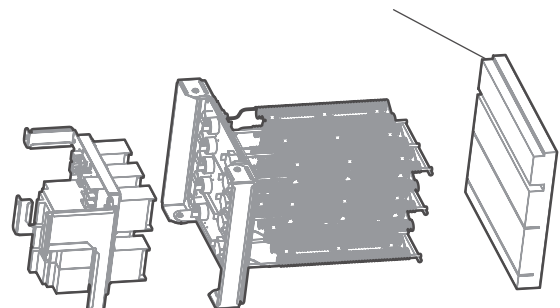

Electric Auxiliary Heat Module installation and Wiring Operation

Step 1

Open the upper cover.

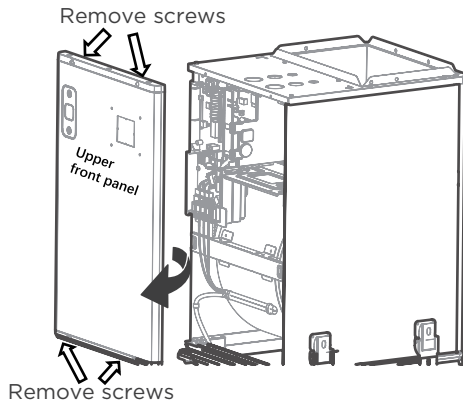

Step 2

Use tools to remove the knock-out holes of upper cover.

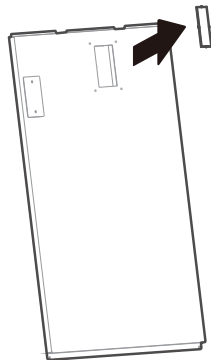

Step 3

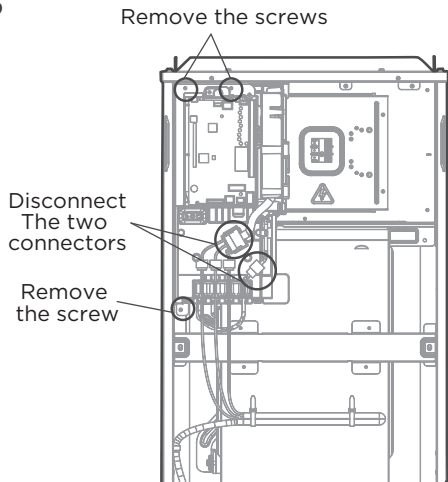

Step 4

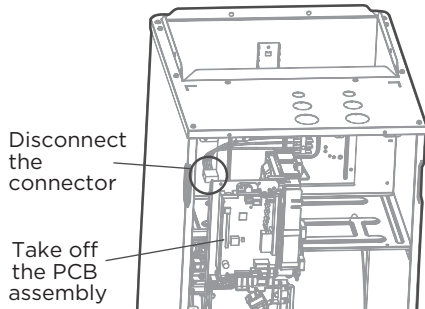

Step 5

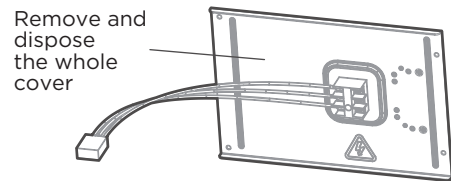
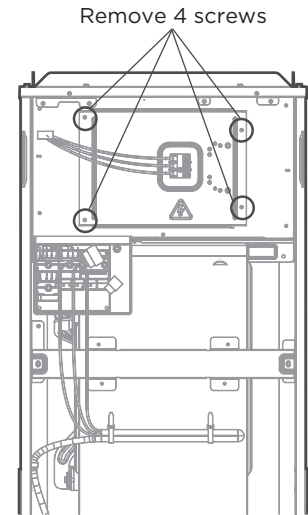

Step 6 turn the handles in the auxiliary Heater.

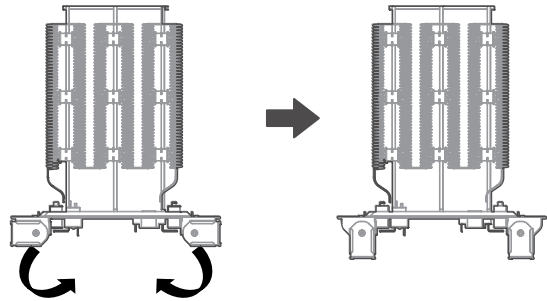

Step 7 hold the two handles together and push the Auxiliary heater Horizontally into the AHU.

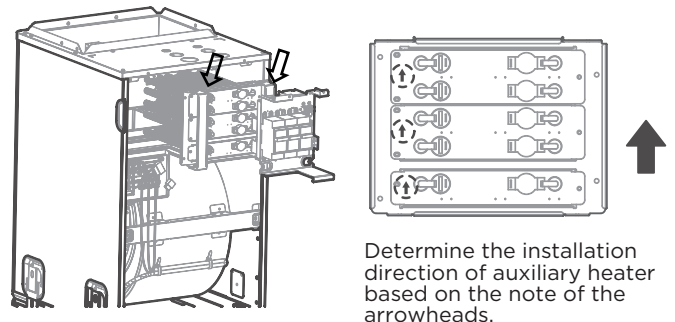

Determine the installation direction of auxiliary heater based on the note of the arrowheads.

Step 8 Turn the handles back and fix the screws.

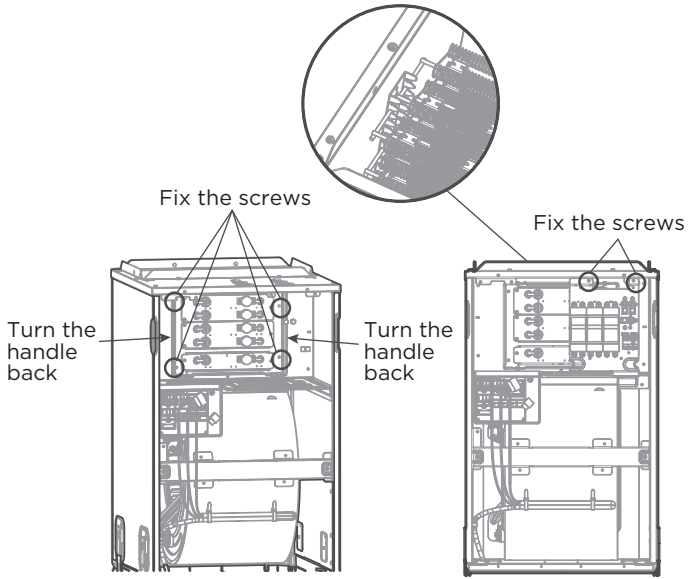

Step 9 Connect the connector from auxiliary heater onto the board assembly according to the wiring diagram.

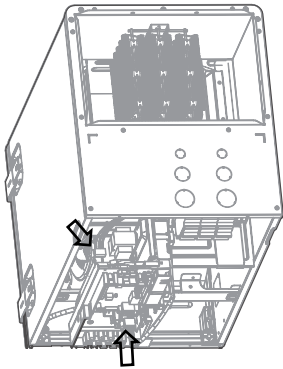

Step 10 Install the PCB back and reconnect the connector. Fix 3 screws.

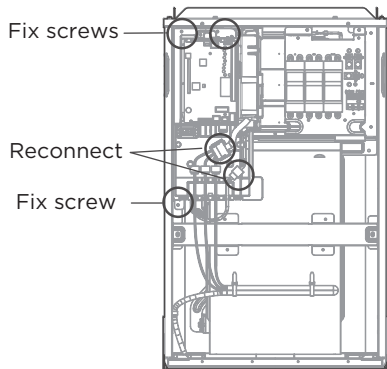

Step 11 Wire according to the wiring diagram. Apply the wiring diagram on the inside cover after wiring is completed for future reference and maintenance.

Step 12 Install the front panel and remove the knockout basing the different heater model.

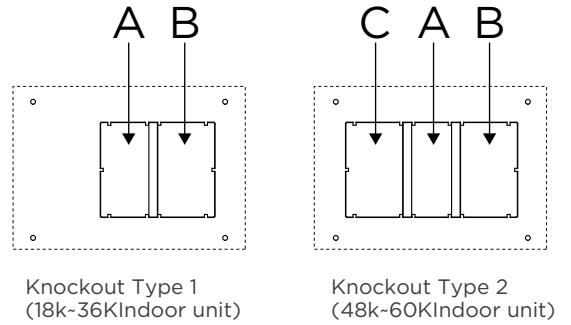
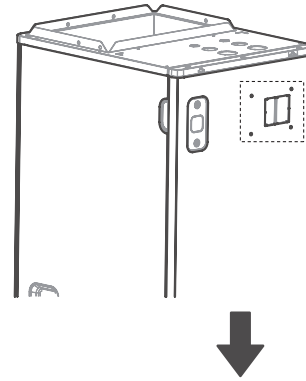

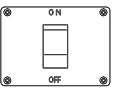
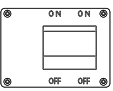
Model	Knockout which needs be removed	Silicone breaker cover
5kw	A	Cover 1 
10kw		
15kw	A+B	Cover 2 
20kw		

Step 13 Fix foam gasket and install the silicone breaker cover with screws.

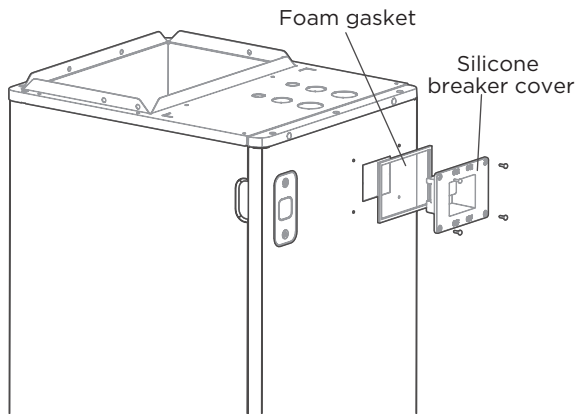

Step 14 After installing the electric auxiliary heat module, apply the circuit breaker label near the silicone breaker cover that was just applied.

CAUTION

Power off before service.

ELECTRICAL SPECIFICATIONS

NOTICE

Electric auxiliary heating wiring diagram packed with the accessories.

If branch circuit wire length exceeds 100ft, consult the local code to determine maximum wire length. Use 2% voltage drop.

After the electric heating wiring is connected, please confirm before power on:

- Check all wiring and ensure secure connection of all wiring.
- Ensure that wire size is properly selected per the local code.

Specifications	Number of circuit breakers	Number of relays	Number of power cord groups	Number of power cord grounding screws
5kW	1	1	2	2
10kW	1	2	2	2
15kW	2	3	3	3
20kW	2	4	3	3

Use copper wire only to connect unit. If other than uncoated (non-plated) 167°F copper wire (solid wire for 10 AWG and smaller, stranded wire for larger than 10 AWG) is used consult applicable tables of the National Electric Code (ANSI/NFPA 70).

NOTICE

The specification may be different between different models, please refer to indoor unit's nameplate.

Auxiliary Heater Electrical Data

Heater Model No.	Heater KW	Internal Circuit Protection	CIRCUIT 1 208/230V			CIRCUIT 2			CIRCUIT 2				
			Heater Amps	MCA (1)	MOP (2)	Heater Amps	MCA (1)	MOP (2)	Heater Amps	MCA (1)	MOP (2)		
CH-PQEH05KW	5	Ckt Bkr	18.0/20.0	23.0/27.0	25.0/30.0	/	/	/	/	/	/	/	/
CH-PQEH10KW	10	Ckt Bkr	36.0/40.0	46.0/53.0	50.0/60.0	/	/	/	/	/	/	/	/
CH-PQEH15KW	15	Ckt Bkr	18.0/20.0	23.0/27.0	25.0/30.0	36.0/40.0	46.0/53.0	50.0/60.0	/	/	/	/	/
CH-PQEH20KW	20	Ckt Bkr	36.0/40	46.0/53.0	50.0/60.0	36.0/40.0	46.0/53.0	50.0/60.0	/	/	/	/	/

Electric auxiliary heating wiring diagram

3KW/5KW HEAT KIT

- :THERMAL LINK
- :THERMAL CUT-OUT, SELF-RESETTING

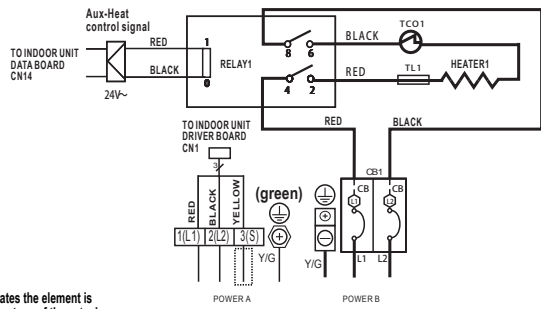

NOTE1: This symbol indicates the element is optional. The wiring type of the actual unit shall prevail.

NOTE2: PLEASE ATTACH THE NAMEPLATE TO THE COVER OF THE ELECTRIC CONTROL BOX. ALL THE ROUND HOLES LOCATED ON THE PLATE REPRESENT NUMBERS. PLEASE REFER TO THE INSTALLATION MANUAL FOR DETAILS.

NOTE3: TO BE WIRED IN ACCORDANCE WITH NEC AND LOCAL CODES.

NOTE4: POWER A,B,C,D ARE DIFFERENT POWERS.

Electric heating is only applicable to 208-230V.

Round hole number	Relay number	Round hole number	Circuit breaker number
○	RELAY 1	○	CB1
○		○	
○		○	
○		○	
○		○	

The wiring mode of power supply A shall be based on the type of original wiring terminal of AHU; for type A, S position must be connected to the outdoor S; for type B, S position shall not be connected. When using 115VAC, connect L1 and L2 (L2 is used as N).

TYPE A	TYPE B

8KW/10KW HEAT KIT

- :THERMAL LINK
- :THERMAL CUT-OUT, SELF-RESETTING

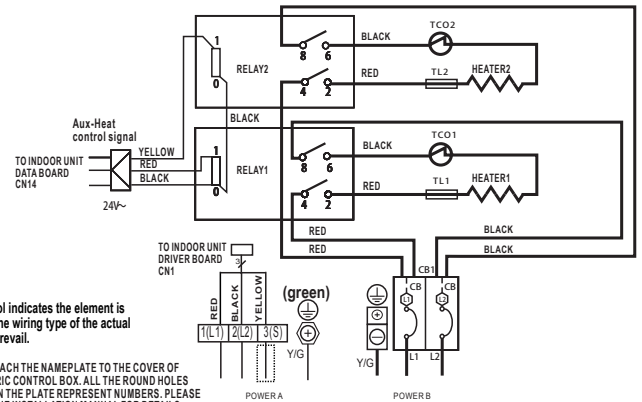

NOTE1: This symbol indicates the element is optional. The wiring type of the actual unit shall prevail.

NOTE2: PLEASE ATTACH THE NAMEPLATE TO THE COVER OF THE ELECTRIC CONTROL BOX. ALL THE ROUND HOLES LOCATED ON THE PLATE REPRESENT NUMBERS. PLEASE REFER TO THE INSTALLATION MANUAL FOR DETAILS.

NOTE3: TO BE WIRED IN ACCORDANCE WITH NEC AND LOCAL CODES.

NOTE4: POWER A,B,C,D ARE DIFFERENT POWERS.

Electric heating is only applicable to 208-230V.

Round hole number	Relay number	Round hole number	Circuit breaker number
○	RELAY 1	○	CB1
○	RELAY 2	○	
○		○	
○		○	
○		○	

The wiring mode of power supply A shall be based on the type of original wiring terminal of AHU; for type A, S position must be connected to the outdoor S; for type B, S position shall not be connected. When using 115VAC, connect L1 and L2 (L2 is used as N).

TYPE A	TYPE B

15KW HEAT KIT

- :THERMAL LINK
- :THERMAL CUT-OUT, SELF-RESETTING

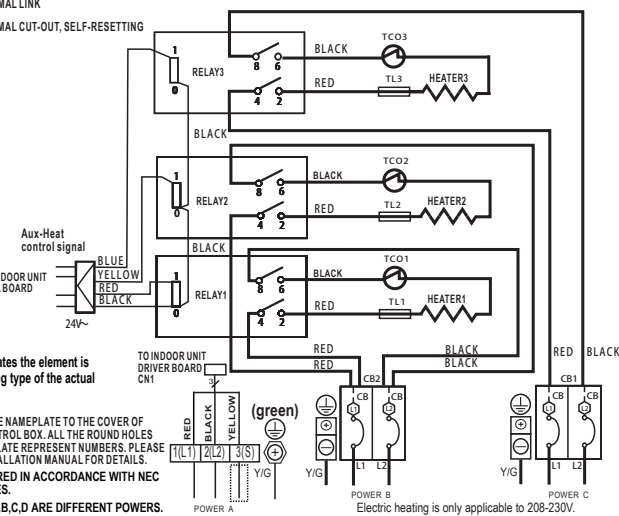

NOTE1: This symbol indicates the element is optional. The wiring type of the actual unit shall prevail.

NOTE2: PLEASE ATTACH THE NAMEPLATE TO THE COVER OF THE ELECTRIC CONTROL BOX. ALL THE ROUND HOLES LOCATED ON THE PLATE REPRESENT NUMBERS. PLEASE REFER TO THE INSTALLATION MANUAL FOR DETAILS.

NOTE3: TO BE WIRED IN ACCORDANCE WITH NEC AND LOCAL CODES.

NOTE4: POWER A,B,C,D ARE DIFFERENT POWERS.

Electric heating is only applicable to 208-230V.

Round hole number	Relay number	Round hole number	Circuit breaker number
○	RELAY 1	○	CB1
○	RELAY 2	○	CB2
○	RELAY 3	○	
○		○	
○		○	

The wiring mode of power supply A shall be based on the type of original wiring terminal of AHU; for type A, S position must be connected to the outdoor S; for type B, S position shall not be connected. When using 115VAC, connect L1 and L2 (L2 is used as N).

TYPE A	TYPE B

20KW HEAT KIT

- :THERMAL LINK
- :THERMAL CUT-OUT, SELF-RESETTING

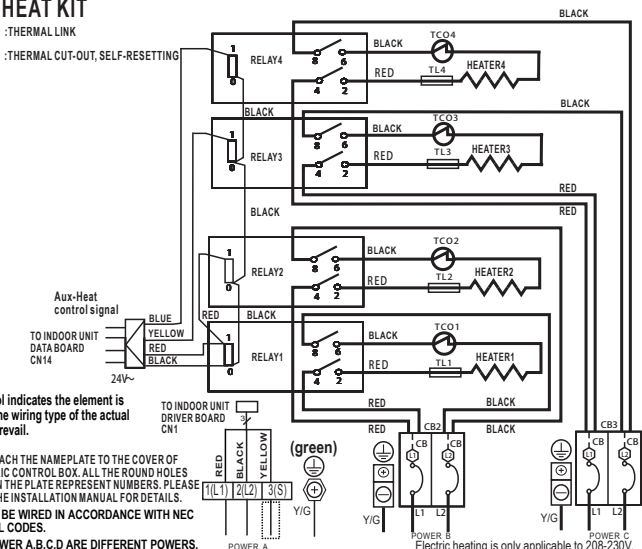

NOTE1: This symbol indicates the element is optional. The wiring type of the actual unit shall prevail.

NOTE2: PLEASE ATTACH THE NAMEPLATE TO THE COVER OF THE ELECTRIC CONTROL BOX. ALL THE ROUND HOLES LOCATED ON THE PLATE REPRESENT NUMBERS. PLEASE REFER TO THE INSTALLATION MANUAL FOR DETAILS.

NOTE3: TO BE WIRED IN ACCORDANCE WITH NEC AND LOCAL CODES.

NOTE4: POWER A,B,C,D ARE DIFFERENT POWERS.

Electric heating is only applicable to 208-230V.

Round hole number	Relay number	Round hole number	Circuit breaker number
○	RELAY 1	○	CB2
○	RELAY 2	○	CB3
○	RELAY 3	○	
○	RELAY 4	○	
○		○	

The wiring mode of power supply A shall be based on the type of original wiring terminal of AHU; for type A, S position must be connected to the outdoor S; for type B, S position shall not be connected. When using 115VAC, connect L1 and L2 (L2 is used as N).

TYPE A	TYPE B



Technical Support

Single & Multi-Zone Mini Splits • PTACs • Portables •
TTWs • Light Commercial A/C Systems

Limited Warranty provided by Cooper&Hunter (hereby referred to as C&H) covers specified products and parts, subject to the following details:

Our warranty:

C&H Limited Warranty applies only to products installed by a licensed HVAC technician.

Product Registration: Products must be registered for Limited Warranty within 60 days of installation by licensed HVAC technician. Products can be registered at www.cooperandhunter.us/warranty. Alternatively, the warranty registration card from the product User's Manual can be filled out and sent in as instructed.

Warranty Coverage: Cooper&Hunter distributor warrants this product against failure due to defect in materials or workmanship under normal use and maintenance as follows. All warranty periods begin on the date of original installation. Damage resulting from failure to use, install or maintain the product in a manner consistent with manufacturer's recommendations shall render the warranty void. Cooper&Hunter, at its discretion, may request a report from a qualified technician prior to honoring a warranty claim. If a part fails due to defect during the applicable warranty period, Cooper&Hunter will provide a new or remanufactured part, at C&H's discretion, to replace the failed defective part at no charge. This Limited Warranty is subject to all provisions, conditions, limitations and exclusions listed below.

- Warranty is provided only to the first original owner of the Product, where it is originally installed, and is not transferable to the subsequent owners
- Limited Warranty applies only to systems properly installed by a state certified or licensed HVAC contractor, under applicable local and state law, in accordance with all applicable building codes and permits, C&H installation and operation instructions and good trade practices
- Warranty applies only to products remaining in their original installation location
- Defective parts must be returned to the distributor through a registered servicing dealer for credit

This warranty gives you specific legal rights. Rights may vary from state to state or province to province. For complete warranty details and duration of your specific product, please visit our website at cooperandhunter.us/warranty and follow the registration instructions.

LIMITATIONS OF WARRANTIES:

ALL IMPLIED WARRANTIES AND/OR CONDITIONS (INCLUDING IMPLIED WARRANTIES OR CONDITIONS OF MERCHANTABILITY AND FITNESS FOR A PARTICULAR USE OR PURPOSE) ARE LIMITED TO THE DURATION OF THIS LIMITED WARRANTY. SOME STATES OR PROVINCES DO NOT ALLOW LIMITATIONS ON HOW LONG AN IMPLIED WARRANTY OR CONDITION LASTS, SO THE ABOVE MAY NOT APPLY TO YOU. THE EXPRESSED WARRANTIES MADE IN THIS WARRANTY ARE EXCLUSIVE AND MAY NOT BE ALTERED, EXTENDED, OR CHANGED BY ANY DISTRIBUTOR, DEALER, OR OTHER PERSON, WHATSOEVER.

Warranty Exclusions: Cooper&Hunter is not responsible for any warranty claim:

1. For equipment installed outside of North America.
2. For equipment not installed according to manufacturer's guidelines.
3. For equipment which has been removed from the original place of installation and reinstalled at another place.
4. If registration information cannot be verified (i.e., invalid license number or wrong information provided).
5. For damages or repairs arising as a result of a faulty installation, inappropriate application, or improper use.
6. For damages or repairs arising from any external perils, out of Cooper&Hunter's control, such as fires, storms, accidents, floods, broken or frozen water pipes, electrical surges, input power with under or overvoltage, lightning, or existence of corrosive substances nearby.
7. For damages or repairs arising from use of non-compatible parts, third-party components, alterations, modifications, or improper applications.
8. For improper service or poor maintenance of the equipment, such as cleaning of all air filters, heat exchangers, fans, and blowers, in addition to any necessary lubrication of internal components and maintenance of external accessories.
9. For changes that can be considered cosmetic, including but not limited to small fin damages, scratches on the unit cover, etc.

10. For resetting of power or the circuit breakers and replacement of other types of fuses, both internal and external.
11. For any damage caused by the use of dirty, recycled, or wrong type of refrigerants and lubricants.
12. For damage due to moisture, air, dust, sand, dirt, etc., that have been allowed into the system.
13. For damage caused by continuing use of the product after a malfunction has been noticed or indicated at the display module, through an error code.
14. For damages or performance issues due to improper matching, product selection, undersizing, oversizing, improper installation, or misuse.
15. For loss or replacement of refrigerant, lubricant, or oil.
16. For labor or any costs associated with labor.

Warranty Begin Date: Warranty begins on the date of registration.

Warranty End Date: Products that have not been registered as instructed above are not covered under Warranty. The Warranty duration will vary from product to product and may have additional extensions granted through promotional benefits. Any part, component or product that is replaced under the terms of this Warranty, will be covered under the same Warranty for the duration in which the original Warranty was applicable. Please visit our website at cooperandhunter.us/warranty and follow the registration instructions to find specific details on your product warranty.

Warranty Procedure: The product owner or technician should contact **Cooper&Hunter Technical Support at (786) 953-6706, Monday to Friday from 9AM to 5PM EST** while the technician is on site servicing the unit. The product may display error codes. The technician should be on site while troubleshooting with the C&H Technical Support Agent so he or she can address symptoms observed, specific electrical and mechanical measurements, and other detailed information that may be required for proper diagnosis.

While technicians may refer to Cooper&Hunter's website or YouTube channel for helpful information, such as manuals and videos based on certain error codes, the technician will need to troubleshoot with the C&H Technical Support Agent for Warranty purposes. Cooper&Hunter is not able to remotely diagnose a product and or offer remedies, without proper diagnosis results.

When contacting Technical Support, the following forms and information need to be provided:

1. Unit's Model & Serial number
2. Date of Unit Installation by a Licensed Technician
3. Installer's EPA License Number
4. Place Unit was purchased

Cooper&Hunter may ask for photos and/or other diagnostic information it deems necessary prior to processing the Warranty claim.

It should be noted that C&H Technical Support Agents troubleshoot on a case-by-case basis, following best practices and procedures to diagnose problems and solutions. Through this process, it is most efficient to diagnose one issue or error code at a time. It is possible that the first suggested solution may or may not solve one problem of multiple failures, in which case the Technician will continue through troubleshooting for remaining issues/error codes.

Cooper&Hunter will furnish a new or refurbished part without any charge for the part itself, for the replacement of any part that has been determined, by Cooper&Hunter, to have failed, at its sole discretion, due to defects in its materials or workmanship under standard use and proper maintenance. The payment of the shipping costs for the part will be the sole responsibility of the owner of the product. Cooper& Hunter reserves the right to ask the owner of the product to return the failed part before or after a replacement part is sent out.

Labor cost, materials and other costs: Any labor costs and/or the costs for the supplies or materials used or purchased in the field for the replacement of the defective part, remain the responsibility of the owner. No other costs involved in diagnosis, lodging, transportation, servicing, repair, replacement, installation, removal, shipping, etc., are to be covered under the Warranty.

Refrigerant: Any costs related to charging, recharging, adjustment, or removal of refrigerant, and the cost of the refrigerant itself, are not covered under any circumstances. All products go through vigorous quality controls at various stations and leave the factory in perfect working and sealed condition. Products are individually tested in highly sensitive helium vacuum chambers for existence of refrigerant leaks. Cooper&Hunter does not cover any claims related to the lack of refrigerant in new products, discovered upon arrival, or during installation, as well as subsequent refrigerant loss occurring at any time afterward.

This Warranty is not transferable. No person or entity is authorized to change the terms and conditions outlined in this Warranty agreement, in any respect, nor to create any additional obligations or liabilities for any party involved.

This warranty agreement supersedes all prior warranty agreements between the parties and constitutes the complete, final and exclusive understanding of the parties with respect to the subject matter. All prior

negotiations, representations, or promises, whether oral or written, of either party shall be deemed to have been merged herein.

If any part of this warranty agreement shall be invalidated for any reason, such part shall be deleted, and the remainder shall be unaffected and shall continue in full force and effect. This Warranty provides you certain legal rights and you may also have other rights, which vary from State to State. Therefore, some of these limitations or exclusions may not apply to you.

States with Express and Implied Warranties: Products in states with Express and Implied Warranties do not need to be registered for C&H Warranty. However, for Warranty support, installation invoice should be provided.

Pursuing legal remedies:

ARBITRATION CLAUSE. IMPORTANT. PLEASE REVIEW THIS ARBITRATION CLAUSE, AS IT AFFECTS YOUR LEGAL RIGHTS.

1. This arbitration clause affects your rights against Cooper&Hunter and any of its employees, agents, affiliates, successors, or assignees, all of whom together are referred to below as “we” or “us” for the simplicity of reference.
2. **ARBITRATION REQUIREMENT: EXCEPT AS STATED BELOW, ANY DISPUTE BETWEEN YOU AND ANY OF US SHALL BE DECIDED BY NEUTRAL AND BINDING ARBITRATION, RATHER THAN ANY COURT OR BY TRIAL BY JURY. ARBITRATION WILL BE HANDLED ONLY ON AN INDIVIDUAL BASIS AND ALL PARTIES EXPRESSLY WAIVE; ANY RIGHTS TO PARTICIPATE AS A CLASS REPRESENTATIVE OR CLASS MEMBER, ANY RIGHTS TO CLASS ARBITRATION OR ANY CONSOLIDATION OF INDIVIDUAL ARBITRATIONS. THE ARBITRATOR WILL BE A MEMBER OF THE AMERICAN ARBITRATION ORGANIZATION.** The meaning of “Dispute” has the broadest possible meaning allowable by law, including any controversy, claim or other dispute, relating to or arising from the purchase of the product, any of the warranties upon the product, or the condition of the product, as well as the determination of the application or the scope of the Arbitration Clause itself. Rights to appeal and discovery are also limited in arbitration based on the rules of the arbitration organizations.
3. **Governing Law:** Effect and procedures of arbitration will be governed by the Federal Arbitration Act (9 U.S.C. § et seq.) rather than any related state law. In case of any substantive warranty, your claims and rights under such substantive warranty will be governed by the applicable law of the state in which Product was purchased.
4. **Location of the Arbitration:** Unless otherwise provided under the applicable law, arbitration hearing will be conducted in the judicial district in Miami-Dade County, Florida.
5. **Costs of the Arbitration:** Unless otherwise provided under the applicable law, each party will be responsible for; its own costs payable to the arbitration organization, and the costs of their attorneys, experts or other fees.
6. **Survival and Enforceability of the Arbitration Clause:** This arbitration clause will survive the expiration or termination of this warranty agreement, indefinitely.



12172024