

Installation Manual

*for
Switch Box*

Models:

**SPSBB-16
SPSBB-28**

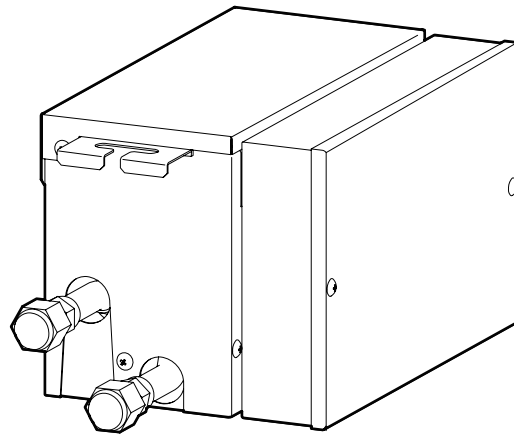

IMPORTANT:

*READ AND UNDERSTAND
THIS MANUAL CAREFULLY
BEFORE INSTALLING THIS
SWITCH BOX.
KEEP THIS MANUAL FOR
FUTURE REFERENCE.*

IMPORTANT NOTICE

- The applicable outdoor unit may be different depending on the product series. Improper combination causes the unit to malfunction and an alarm will be triggered. Be sure to confirm with the product catalogue before installation.
- Cooper&Hunter pursues a policy of continuous improvement in the design and performance of products to meet regulatory requirements and industry standards. Therefore, Cooper&Hunter reserves the right to revise specifications without notice.
- Cooper&Hunter cannot anticipate every possible circumstance that might involve a potential hazard.
- This heat pump air conditioner is designed for standard air conditioning applications only. Do not use this heat pump air conditioner for other purposes, such as drying clothes, refrigerating foods, or for any other cooling or heating process.
- Do not install the unit outdoors. Do not install the unit in the following places. It may cause a fire, deformation, corrosion or failure.
 - * Places where there are high levels of oil mist (including machinery oil).
 - * Places where there are high alkalinity levels (i.e., chlorine or bromine such as over hot tubs, etc.).
 - * Places where flammable gases or liquids may be used or generated.
 - * Places with a high concentration of salts, salty mists or sprays (such as over salt-water aquariums).
 - * Places with an atmosphere of high nuisance dust. Places with organic solvent atmospheres, such as painting and cleaning locations.
- Do not install a unit in the place where condensate water can leak onto the unit or electrical device failures may occur.
- Pay attention to the following points when the unit is installed in a hospital or other facility where electromagnetic waves generate from medical equipment.
 - * Do not install the unit in places where electromagnetic waves radiate to the electrical box, wired controller cable or wired controller.
 - * Install the unit at least 10 ft (3m) away from electromagnetic waves or interferences such as a radio.
- The installer and system specialist shall secure against leakage according to local regulations or standards. This system has both high and low pressure refrigerant and, as such, comprises a pressurized system. Never loosen threaded joints while the system is under pressure and never open pressurized system parts.
- No part of this manual may be reproduced without written permission from Cooper&Hunter.
- It is assumed that this heat pump air conditioner will be operated and serviced by English speaking people. If this is not the case, the distributor or dealer can provide or add safety, caution and operating signs in the native language.
- If you have any questions, contact your distributor.
- This manual describes the features of this heat pump air conditioner as well as for other models.
- This appliance is intended to be used by expert or trained users in shops, in light industry and on farms, or for commercial use by lay persons.

This manual should be considered as a permanent part of the air conditioning equipment and should remain with the air conditioning equipment.

CHECKING PRODUCT RECEIVED

- Upon receiving this product, inspect it for any shipping damage.
Inspect all electrical connections. Connections must be clean and tight at the terminals.
Claims for damage either apparent or concealed, should be filed immediately with the shipping company.
NOTE: Rough handling may dislocate internal components.
- Check the model number, electrical characteristics (power supply, voltage and frequency) and accessories to determine if they are correct with the ordering and shipping information, to ensure the correct unit has been shipped.
To minimize the possibility of damage after inspection, the units should be installed and reassembled as soon as possible.

The standard installation and general use of this unit is explained in this manual.

Although common processes and procedures for installing units are presented in this manual, its use for installation of units otherwise indicated in this manual is not recommended. Please contact your local agent, as the occasion arises.

Our liability shall not cover defects arising from the alteration performed by a customer without our consent in a written form.

SAFETY SUMMARY

Signal Words

- Signal words are used to identify levels of hazard seriousness.
Definitions for identifying hazard levels are provided below with their respective signal words.

 : DANGER indicates a hazardous situation which, if not avoided, will result in death or serious injury.

 : WARNING indicates a hazardous situation which, if not avoided, could result in death or serious injury.

 : CAUTION used with the safety alert symbol, indicates a hazardous situation which, if not avoided, could result in minor or moderate injury.

 : NOTICE is used to address practices not related to personal injury.

NOTE : NOTE is useful information for operation or maintenance.

SAFETY SUMMARY

DANGER

- Do not perform installation work, refrigerant piping work, condensate pump, or condensate piping and electrical wiring connection without referring to the installation manual. If the instructions are not followed, it may result in a water leakage, electric shock or a fire.
- Use the specified non-flammable refrigerant (R410A) for the outdoor unit in the refrigerant cycle. Charge only R410A into the unit. Do not charge other materials into the unit such as hydrocarbon refrigerants (propane), oxygen, flammable gases (acetylene) or poisonous gases when installing, maintaining and moving the unit. These flammables are extremely dangerous and may cause an explosion, a fire, or injury. As originally manufactured, this unit contains refrigerant installed by Cooper&Hunter. Our company uses only refrigerants that have been approved for use in the unit's intended country or market. Cooper&Hunter's distributors similarly are only authorized to provide refrigerants that have been approved for use in the countries or markets they serve. The refrigerant used in this unit is identified on the unit's faceplate and/or in the associated manuals. Any additions of refrigerant into this unit must comply with the country's requirements with regard to refrigerant use and should be obtained from Cooper&Hunter distributors. Use of unapproved refrigerant substitutes will void the warranties and can cause injury or death.
- Do not pour water into the indoor or outdoor unit. These units are equipped with electrical parts. Exposure to water may cause a serious electrical shock.
- Users are not allowed to open the service cover or access panel for the indoor or outdoor units by themselves. For professional technicians, please turn OFF the main power supply before operating.
- Do not touch or adjust safety devices inside the indoor unit or outdoor units. If these devices are touched or readjusted, it may cause a serious accident.
- Carefully check for escaping refrigerant gas. If there is significant leakage, it can cause difficulty in breathing. Turn OFF the main switch, and contact your service contractor if refrigerant leakage occurs.
- Make sure that the refrigerant leakage test is performed.
Refrigerant (fluorocarbon) for this unit is incombustible, non-toxic and odorless.
However if the refrigerant is leaked and comes in contact with fire, toxic gas will generate.
Because fluorocarbon is heavier than air, the floor surface will be filled with it, which could cause suffocation.
- The installer and system specialist shall secure against refrigerant leakage according to local regulations or standards.
- Use ELB with medium or higher sensing speed (ELB with an operating time of 0.1 seconds or less), or electric shock or fire may arise.
- For installation, the refrigerant piping must be firmly connected before the operation of compressor. For repair, the refrigerant piping must be moved, handled and removed after the stop of compressor.
- Please don't short-circuit the protective device (e.g., the pressure switch, etc.) during operation, since this may cause fire or explosion.

SAFETY SUMMARY

⚠ WARNING

- Do not use any sprays such as insecticide, lacquer, hair spray or other flammable gases within approximately 4 ft (1.3m) from the system.
- If the circuit breaker or fuse is often activated, stop the system and contact your service contractor.
- Check that the ground wiring is securely connected. If the unit is not correctly grounded, it may cause electric shock. Do not connect the ground wiring to gas piping, condensate piping, lighting conductor or ground wiring for telephones.
- Before performing any brazing work, check to ensure that there is no flammable material around. When using refrigerant, be sure to wear leather gloves to prevent injury from cold.
- Insulate electrical wiring, condensate piping, and electrical components from threats posed by burrowing animals and temperature extremes. Failure to do so can, over time, deteriorate system performance.
- Secure the cables. External forces on the terminals could lead to a fire.
- Tighten the flare nut with a torque wrench in the specified manner. Do not apply excessive force to the flare nut when tightening. If you do, the flare nut can crack and refrigerant leakage may occur.
- When maintaining, relocating or disposing of the unit, dismantle the refrigerant piping after the compressor stops.
- Highly dangerous electrical voltages are used in this system. Carefully refer to the wiring diagram and these instructions when wiring. Improper connections and inadequate grounding can cause serious injury or death.
- Perform all electrical work in strict accordance with this installation and maintenance manual and all relevant regulatory standards.
- Use specified cables between units.
- Be sure to install circuit breakers (ground fault interrupter, isolating switch, molded case circuit breaker and so on), with the specified capacity. Ensure that the wiring terminals are tightened securely to recommended torque specifications. If a circuit breaker or fuse is frequently activated, shut down the system and contact your service contractor.
- Clamp electrical wires securely with a cable clamp after all wiring is connected to the terminal block. In addition, run wires securely through the wiring access channel.
- When installing the power lines, do not apply tension to the cables. Secure the suspended cables at regular intervals, but not too tightly.
- After stopping operation, be sure to wait at least five minutes before turning off the main power switch. Otherwise, water leakage or electrical breakdown may result. Disconnect the power supply completely before attempting any maintenance for electrical parts. Check to ensure that no residual voltage is present after disconnecting the power supply.
- Insulate the refrigerant pipe connection to prevent condensation.
- Be sure to attach the cover so that it fits securely on the electrical box without any gaps. Secure the cover with screws.
- This appliance is not intended for use by persons (including children) with reduced physical, sensory or mental capabilities, or lack of experience and knowledge, unless they have been given supervision or instruction concerning use of the appliance by a person responsible for their safety.
- Children should be supervised to ensure that they do not play with the appliance.
- If the supply cord is damaged, it must be replaced by the manufacturer, its service agent or similarly qualified persons in order to avoid a hazard.
- Cancer and reproductive harm-www.P65Warnings.ca.gov.
- Take measures to ensure that the refrigerant limitations in ASHRAE Standard 15 (Canada: B52) or other local codes, are followed. If refrigerant gas has leaked during the installation work, ventilate the room immediately.

⚠ CAUTION

- Do not step on the unit.
- Do not put any foreign material on the unit or inside the unit.
- Provide a strong and correct foundation so that:
 - The outdoor unit is not on an incline.
 - Abnormal sound does not occur.
 - The outdoor unit will not fall down due to a strong wind or earthquake.
 - A warning to assure that partial units shall only be connected to an appliance suitable for the same refrigerant.
 - This unit <model SPSBB-16 and SPSBB-28> is a partial unit air conditioner, complying with partial unit requirements of this International Standard, and must only be connected to other units that have been confirmed as complying to corresponding partial unit requirements of this International Standard.

NOTICE

- Be careful that moisture, dust, or variant refrigerant compounds not enter the refrigerant system during installation work. Foreign matter could damage internal components or cause blockages.
- Do not install the indoor unit, outdoor unit, wired controller and cable within approximately 9.84 ft (3m) of strong electromagnetic wave radiators such as medical equipment.
- After a long shutdown, apply power to the outdoor unit(s) at least 12 hours prior to operation of the system for preheating of the compressor oil.
- The A-weighted emission sound pressure level is below 70 dB(A);

NOTE

- It is recommended that the room is ventilated every three to four hours.
- The heating capacity of the heat pump unit is decreased according to the outdoor air temperature. Therefore, it is recommended that auxiliary heating equipment be used in the field when the unit is installed in a low temperature region.

CHECKING PRODUCT RECEIVED

- Upon receipt of this product, check it for any shipping damage. Claims for damage, either apparent or concealed, should be filed immediately with the shipping company. Check the model number, electrical parameters (power supply, voltage, and frequency) and accessories to determine if they are correct. Please contact your local dealer in case of problem.

Our company shall not be held responsible for any consequence arising from the modification to equipment without our written consent.

TABLE OF CONTENTS

1. Safety Summary	1
2. Structure	1
2.1 Dimensions.....	1
2.2 Refrigeration Cycle.....	2
2.3 Necessary Tools and Instrument List for Installation	3
3. Transportation and Handling.....	3
3.1 Transportation	3
3.2 Handling of Switch Box.....	3
3.3 Combination of Switch Box and Indoor Unit.....	3
4. Switch Box Installation	4
4.1 Factory-Supplied Accessories	4
4.2 Initial Check	5
4.3 Suspension Bolts.....	6
4.4 Installation	7
4.4.1 Changing the Location of the Electrical Box.....	7
4.4.2 Marking of the Positions of the Suspension Bolts and Wiring Connections	8
4.4.3 Mounting and Hanging the Switch Box.....	8
5. Refrigerant Piping Work.....	9
5.1 Refrigerant Piping.....	9
5.2 Refrigerant Piping Work	11
6. Electrical Wiring	15
6.1 General Check	15
6.2 Electrical Wiring Connection	16
6.3 Electrical Wiring.....	17
6.4 Setting of DIP Switches.....	19
7. Test Run.....	20
8. Safety and Control Device Setting.....	21

1. Safety Summary

! WARNING

- Do not perform installation work, refrigerant piping work or electrical wiring connection without referring to our installation manual.
- Check that the ground wire is securely connected.
- Connect a fuse of specified capacity.

! CAUTION

Do not install the Switch Box and cable within approximately 310 ft (m) from strong electromagnetic wave radiators such as medical equipment.

2. Structure

2.1 Dimensions

SPSBB-16

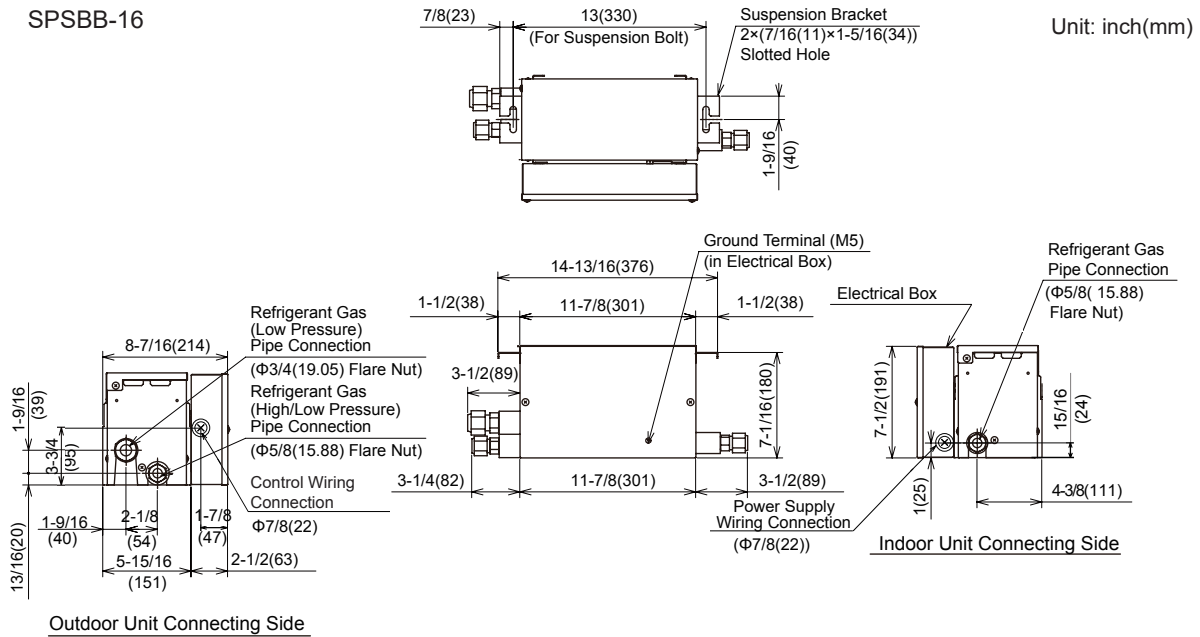

Specification

Model	SPSBB-16
Power Supply	208/230V~60Hz
Power Consumption	16.1Btu/h(5.6W)
Refrigerant	R410A
Net Weight	13.9 lbs(6.3kg)
Number of Connectable Indoor Unit	1 to 8
Number of Indoor Unit Total Capacity	6.0HP or less (Max. 54kBtu/h) (Max. 16kW) (Max. 4.5RT)

Figure 2.1 Dimensions of Switch Box (1)

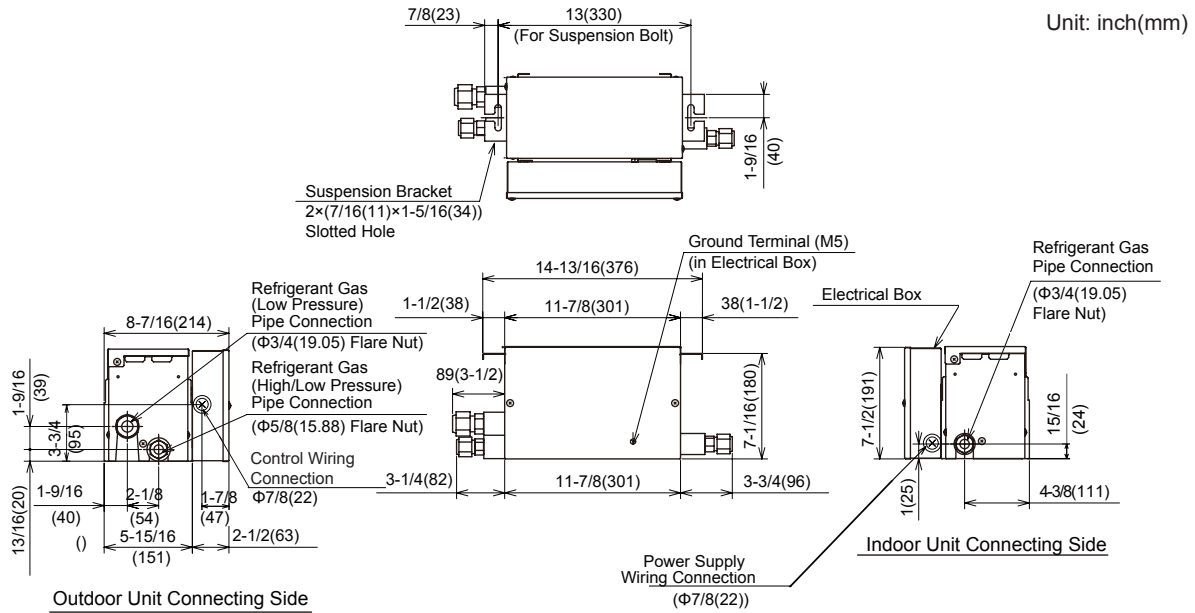

Specification

Model	SPSBB-28
Power Supply	208/230V~ 60Hz
Power Consumption	16.1Btu/h(5.6W)
Refrigerant	R410A
Net Weight	6.4kg (14.1 lbs)
Number of Connectable Indoor Unit	1 to 8
Number of Indoor Unit Total Capacity	10.0HP or less (Max. 96kBtu/h) (Max. 28KW) (Max. 8.0RT)

Figure 2.2 Dimensions of Switch Box (2)

2.2 Refrigeration Cycle

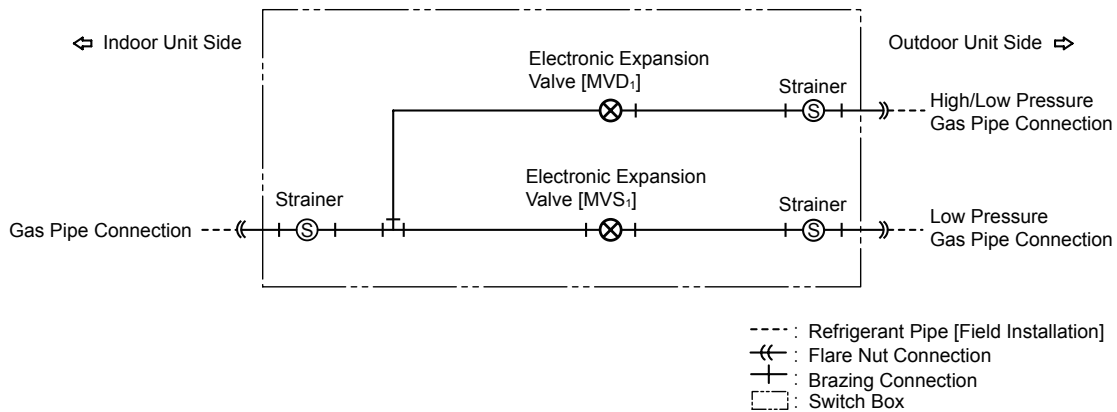

Figure 2.3 Refrigeration Cycle Diagram

2.3 Necessary Tools and Instrument List for Installation

No.	Tool	No.	Tool
1	Handsaw	11	Wrench
2	Phillips Screwdriver	12	Charging Cylinder
3	Vacuum Pump	13	Manifold Gauge
4	Refrigerant Gas Hose	14	Wire Cutter
5	Megohmmeter	15	Gas Leak Detector
6	Copper Pipe Bender	16	Level
7	Manual Water Pump	17	Crimper for Solderless Terminals
8	Pipe Cutter	18	Hoist (for Indoor Unit)
9	Brazing Kit	19	Ammeter
10	Hex Wrench	20	Voltage Meter

NOTE:

Use tools and measuring instruments (vacuum pump, refrigerant hose, charging cylinder, and manifold gauge) exclusively for the refrigerant R410A.

3. Transportation and Handling

3.1 Transportation

Transport the product as close to the installation location as practicable before unpacking.



Do not put any material on the product.

3.2 Handling of Switch Box



Do not put any foreign material into the indoor unit and check to ensure that none exists in the Switch Box before the installation and test run. Otherwise, a fire or failure, or something similar may occur.



Be careful not to damage insulation materials of unit's surface when lifting.

3.3 Combination of Switch Box and Indoor Unit Combination is as follows.

Table 3.1 Combination of Indoor Unit

Model		SPSBB-16	SPSBB-28
Number of Branch (for Indoor Unit)		1	1
Single Unit per Branch	Maximum Total Capacity of All Connected Indoor Units	6.0HP (Max. 54kBTu/h) (Max. 16.0kW) (Max. 4.5RT)	10.0HP or less (Max. 96kBTu/h) (Max. 28.0kW) (Max. 8.0RT)
Multiple Units per Branch (*1)	Maximum Number of Connected Indoor Units per Branch	8	8
	Maximum Total Capacity of All Connected Indoor Units	6.0HP (Max. 54kBTu/h) (Max. 16.0kW) (Max. 4.5RT)	10.0HP or less (Max. 96kBTu/h) (Max. 28.0kW) (Max. 8.0RT)

(*1) When multiple indoor units are connected to the same Switch Box, they are controlled with the same operation mode.

NOTES:

- Exceeding the total capacity may cause insufficient performance and abnormal sound. Be sure to connect the Switch Box within the allowable total capacity.
- If the indoor unit total capacity is 96kBTu/h(28kW, 8.0RT) for SPSBB-28, the performance may decrease approximately.

4. Switch Box Installation

DANGER

- Do not install the Switch Box in a flammable environment to avoid fire or an explosion.

WARNING

- Check to ensure that the ceiling slab is strong enough.
- Do not install the Switch Box outdoors. If installed outdoors, an electric hazard or electric leakage may occur.
- Installation **WARNING**: Ensure that all safety features, disconnects and interlocks are in place and functioning properly prior to putting the equipment into operation. Never by-pass or jump-out any safety device or switch.

4.1 Factory-Supplied Accessories









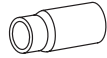
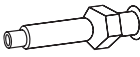
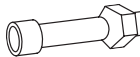
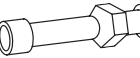
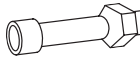
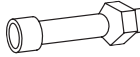

Check to ensure that the following accessories are packed with the Switch Box.

NOTE

If any of these accessories are not packed with the unit, please contact your distributor.

Table 4.1 Factory-Supplied Accessories

Unit: inch (mm)

No.	Accessory	SPSBB-16	Q'ty	SPSBB-28	Q'ty
(1)	Reducer	ID 5/8 (ID 15.88) 	1	-	-
(2)	Accessory Pipe (for Flare Nut)	OD 1/2 (OD 12.7) 	2	ID 7/8 (ID 22.4) 	2
(3)		ID 3/4 (ID 19.3) 	1	ID 3/4 (ID 19.3) 	2
(4)		-	-	ID 3/4 (ID 19.3) 	1
(5)		ID 5/8 (ID 16)		2	
(6)	ID 13/16 (ID 20)		1	-	-
(7)	Insulation Material	-	-		2
(8)	ID 1-1/2 (ID 38)		2		1
(9)	ID 1-11/16 (ID 43)		1		2
(10)	Clamp		6		6

4.2 Initial Check

- Install the Switch Box with a proper clearance around it for maintenance working space, as shown in Figure 4.1 below.

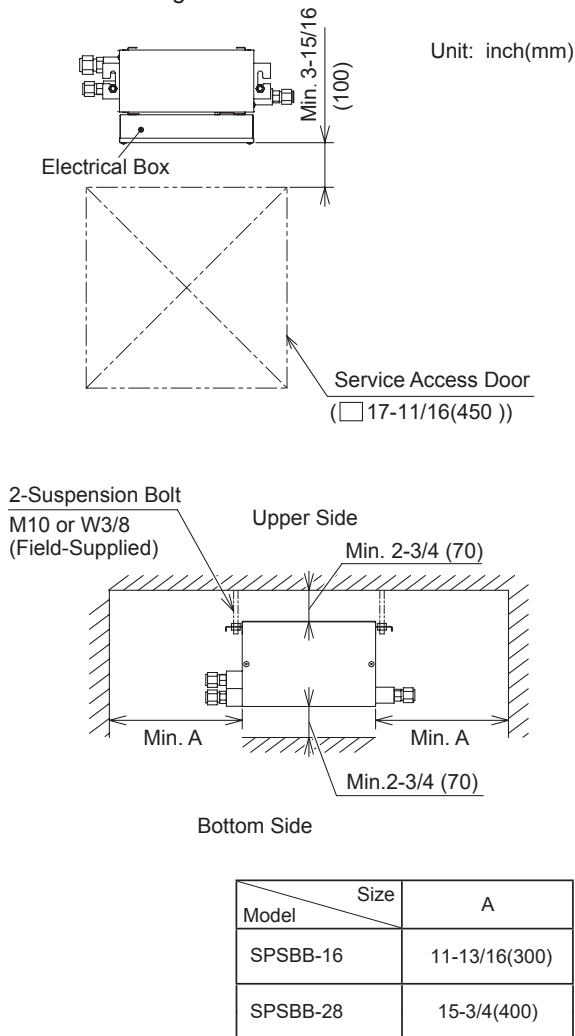

Figure 4.1 Service Space

- Check to ensure that the ceiling is sufficiently strong to sustain the Switch Box. If the ceiling is weak, abnormal sound and vibration may occur.
- When the electronic expansion valve in the Switch Box is activated, a change in the typical refrigerant flow sounds may be heard or perceived from the Switch Box. Take the following action to minimize the sound.
 - (A) Install the Switch Box inside the ceiling. As for the ceiling material, select a material like a plasterboard at least 1 inch (9mm), which minimizes operation sound.
 - (B) Do not install the Switch Box in a place near bedrooms or hospital rooms.
- When the operation is changed to cooling/heating mode, a change in the typical refrigerant flow sounds may be heard or perceived from the Switch Box . Therefore, install the Switch Box in the ceiling of the corridor so that the refrigerant flowing sound may not be heard in the room.
- Do not install the Switch Box in a hot or humid place, such as a kitchen, to prevent condensation on the outer surface of the Switch Box . When installing the Switch Box in such places, apply additional insulation.
- Pay attention to the following points when the Switch Box is installed in a hospital or other facility where there are electronic waves from medical equipment.
 - (A) Do not install the Switch Box where the electromagnetic wave is directly radiated to the electrical box or communication cable.
 - (B) Install the Switch Box and components as far as practicable or at least 10 ft(3m) from the electromagnetic wave radiator.
 - (C) Install a noise filter when the power supply emits harmful noises.
- Ensure the installation place is convenient for the refrigerant piping or electrical wiring connection.
- Do not drill, or drive screws into the cabinet. Use only mounting points provided.

4.3 Suspension Bolts

Step 1

- (1) Select a final location and installation direction of the Switch Box. Pay careful attention to the space for the piping, wiring and maintenance.
- (2) Mount suspension bolts.
- (3) Mount the suspension bolts in the slotted hole on the electrical box side as shown in Figure 4.2.
- (4) Contact a qualified contractor or carpenter for the ceiling treatment.

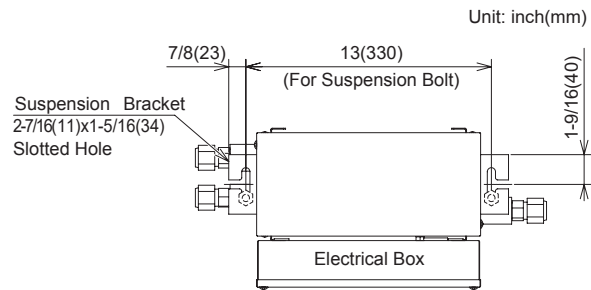
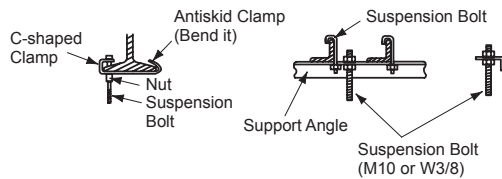

Figure 4.2 Position of Suspension Bolts

Step 2

Mount suspension bolts, as shown in Figure 4.3.

● For Steel Beam



● For Wooden Beam

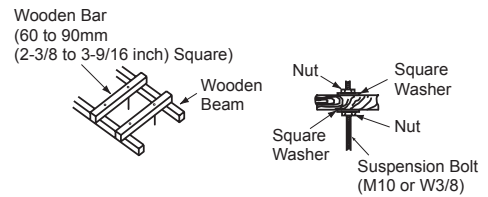

● For Concrete Slab

(1) Hole-In Anchor

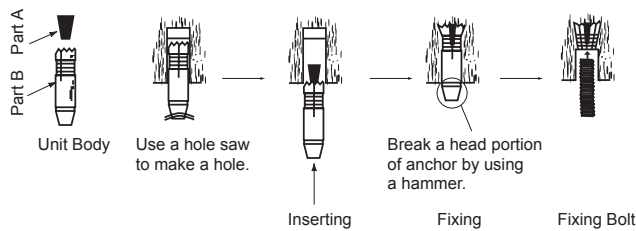

● For Reinforcing Steel

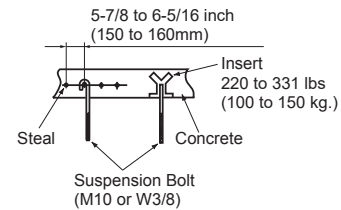

(2) Resin Capsule

Use the resin capsule within the warranty period. Resin capsules deteriorate over time and should be used within six months of the manufacturing date.

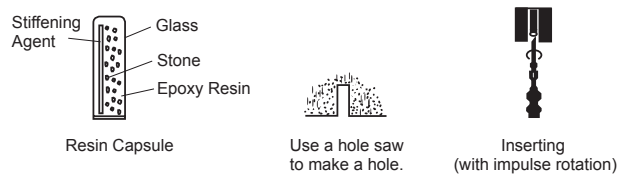

After inserting, do not rotate or put any force until resin is hardened. Required time is as shown in the table at right.

Use a suspension bolt with 30 to 45° sloping edge.

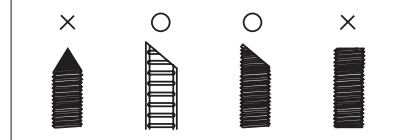

Ambient Temp.	Time
68°F (20°C)	Min. 30min.
59°F (15°C)	Min. 1hr.
50°F (10°C)	Min. 2hr.
41°F (5°C)	Min. 4hr.
32°F (0°C)	Min. 8hr.

NOTE:

- Use a suspension bolt (W3/8, Metric screw thread: M10).
- Prepare washer and nut.

Figure 4.3 Mounting of Suspension Bolts

4.4 Installation

4.4.1 Changing the Location of the Electrical Box

Depending on the installation space, changing the location of the electrical box is available. When changing the location of the electrical box, follow the procedures below:

- (1) Remove the service cover for the electrical box.
- (2) Remove the service cover for the electronic expansion valve.
- (3) Remove the electrical box.
- (4) Remove the wiring from the wire clip and edge saddle, and move the electrical box. After moving the electrical box, put the wiring into the edge saddle and bound with the wire clip. (Refer to "Enlarged View of A" below.)
- (5) Mount the electrical box.
- (6) Rotate the service cover for the electronic expansion valve 180 degrees and mount it.
- (7) Mount the service cover for the electrical box.

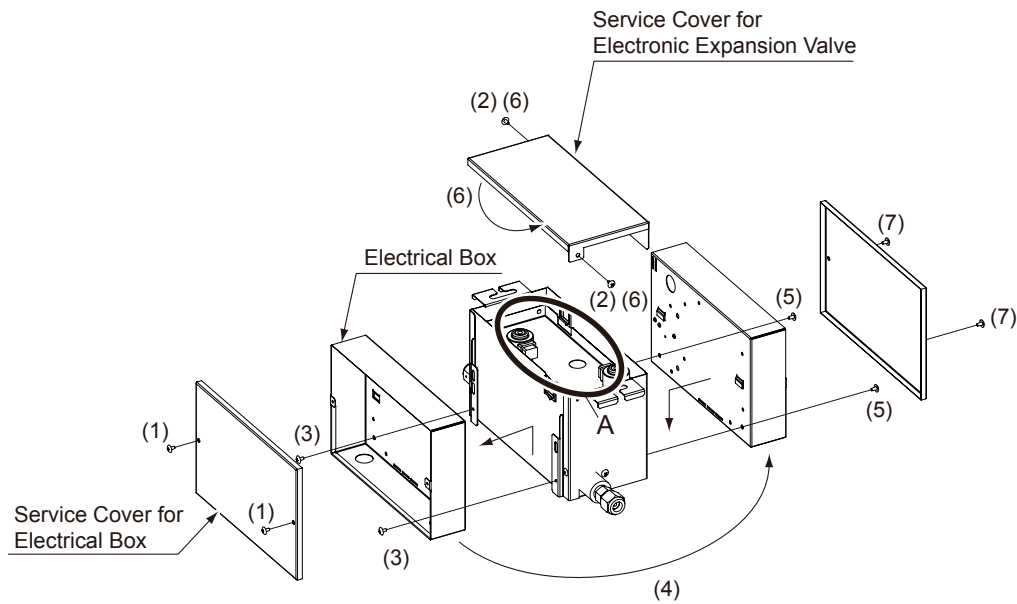

Enlarged View of A

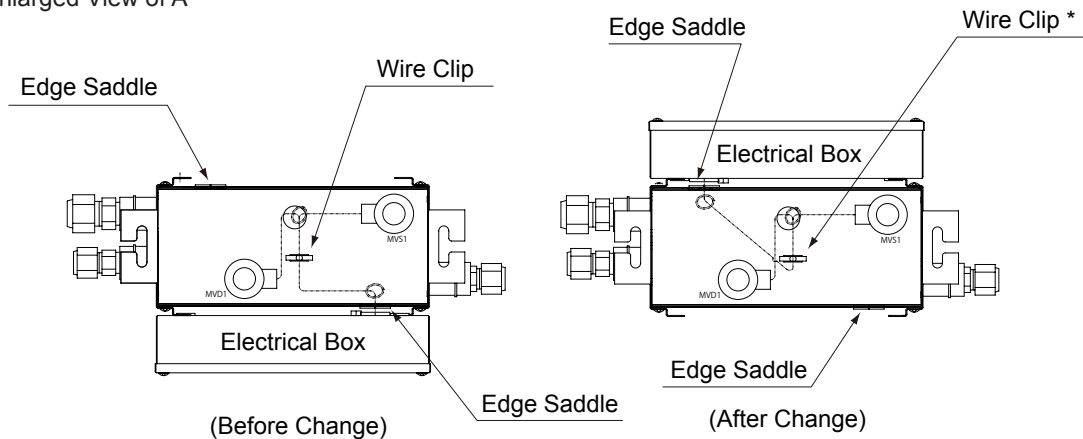

* Make sure that the wiring is bound with the wire clips in order to prevent the electrical box from entering water.

4.4.2 Marking of the Positions of the Suspension Bolts and Wiring Connections

- (1) Mark the positions of the suspension bolts, refrigerant piping connections and wiring connection.
- (2) Installation dimensions are shown in Figure 2.1 and 2.2.

4.4.3 Mounting and Hanging the Switch Box

- (1) Put nuts on each of the two suspension bolts before hanging the Switch Box, as shown in Figure 4.4.
 - * Mounting washers are required in order to affix the suspension bracket to the suspension bolt.

Field-Supplied Parts

- * Suspension Bolt: 2-M10 or W3/8
- * Nut: 6-M10 or W3/8
- * Washer: 4-M10 or W3/8

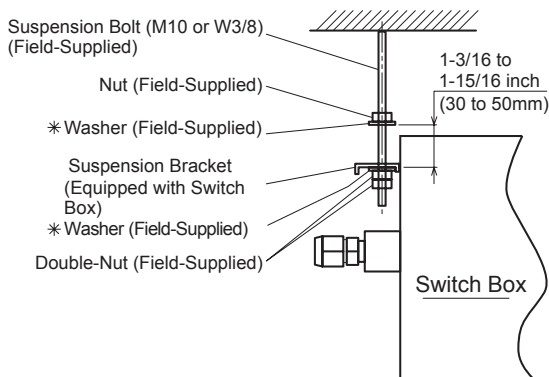

Figure 4.4 Suspension

(2) Hanging the Switch Box

- (a) Hang the Switch Box by putting hands on the bottom of the cabinet.
- (b) Insert the suspension bolt into the groove part of the suspension bracket as shown in Figure 4.5. Ensure that the washers are correctly affixed to the suspension bracket.
- (c) After the hanging work, the piping and wiring connection work is required inside the ceiling in the gap between the roof and ceiling so it is not visible. Therefore, determine the drawing direction of the pipe after selecting the installation location of the Switch Box. Before doing the hanging work, carry out the piping and wiring work up to the connecting positions.
- (d) Keep the Switch Box level to the ceiling surface. If the Switch Box is not level, a malfunction may occur.
- (e) Tighten the nuts of the suspension bolt with the suspension bracket after adjustment is completed. Adhesive must be applied to the nuts in order to prevent them from loosening.

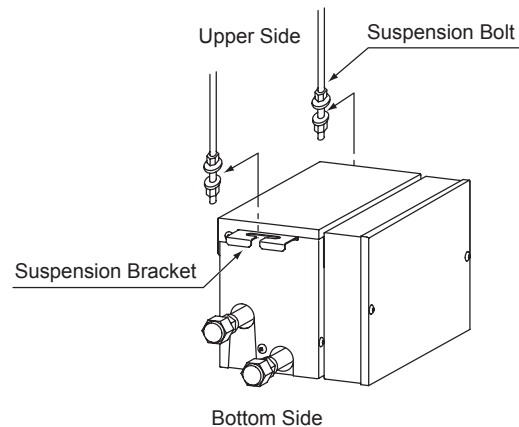

Figure 4.5 Hanging Method

5. Refrigerant Piping Work



Use the specified non-flammable refrigerant (R410A) for the outdoor unit in the refrigerant cycle. Do not charge material other than R410A into the unit such as hydrocarbon refrigerants (propane or something similar), oxygen, flammable gases (acetylene or etc.) or poisonous gases when installing, maintaining and moving. These flammables are extremely dangerous and may cause an explosion, a fire, and injury.

- Flaring Dimension
Perform the flaring work as shown below.

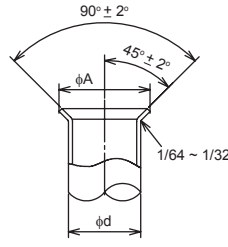

Diameter (φd)	inch (mm)	
	A	R410A
1/4 (6.35)	+0 -0.02(-0.4)	0.36 (9.1)
3/8 (9.52)		0.52 (13.2)
1/2 (12.7)		0.65 (16.6)
5/8 (15.88)		0.78 (19.7)
3/4 (19.05)		(*)

(*) It is impossible to perform the flaring work with 1/2H material. In this case, use an accessory pipe (with a flare).

5.1 Refrigerant Piping

- (1) Prepare locally-supplied copper pipes.
- (2) Select clean copper tubes making sure there is no dust or moisture inside the tubes. Before connecting pipes, blow the inside of the tubes with nitrogen or dry air, to remove any dust or foreign materials.
- (3) Select the piping size as shown in the tables below. Furthermore, check for the flare nut and flaring dimension according to the following figure and table.

- Joint Selection
When using 1/2H material and the flaring work is not available. In this instance, use a joint selected from the chart below.

Minimum Thickness of Joint inch(mm)

Diameter	R410A
1/4 (6.35)	0.020 (0.5)
3/8 (9.52)	0.024 (0.6)
1/2 (12.7)	0.028 (0.7)
5/8 (15.88)	0.031 (0.8)
3/4 (19.05)	0.031 (0.8)
7/8 (22.2)	0.035 (0.9)
1 (25.4)	0.037 (0.95)
1-1/8 (28.58)	0.039 (1.0)
1-1/4 (31.75)	0.043 (1.1)
1-1/2 (38.1)	0.053 (1.35)
1-5/8 (41.28)	0.057 (1.45)

Flare Nut Dimension B inch(mm)

Diameter	R410A
1/4 (6.35)	11/16 (17)
3/8 (9.52)	7/8 (22)
1/2 (12.7)	1 (26)
5/8 (15.88)	1-1/8 (29)
3/4 (19.05)	1-7/16 (36)

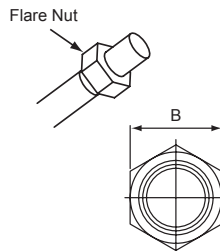

NOTICE

- Cautions for Refrigerant Pipe Work (Example)

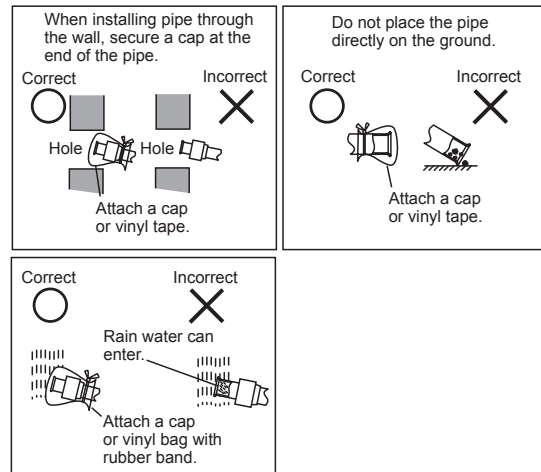

NOTE:

Do not use a joint other than those specified in the table above.

- Cautions for Piping Connection Work

- (a) Connect the indoor/outdoor connecting pipes. Secure the pipes and do not touch other objects, such as ceilings for example. (Otherwise, abnormal sound may be heard due to the vibration of the piping.)
- (b) Apply refrigerant oil slightly on the sheet surface of the pipe and flare nut before the flaring work. Then tighten the flare nut with the specified tightening torque using two wrenches. Always use a back-up wrench to prevent twisting of the copper piping within the unit assembly. Perform the flaring work on the liquid piping side before the gas piping side. Check the gas leakage after the flaring work.

NOTE:

Refrigerant oil is field-supplied.
[Ethereal Oil FVC50K, FVC68D (Idemitsu Kousan Co. Ltd.)]

- (c) When temperature and humidity inside the ceiling exceed 80°F(27°C) /RH, relative humidity, 80%, apply additional insulation approximately 13/16 inch (20mm) thickness to the accessory insulation. It prevents condensation on the surface of the insulation (refrigerant pipe only) and possible damage to electronic components.
- (d) Perform the air-tight leakage test 601 psi (4.15MPa) for the test pressure. Refer to the Technical Manual for the Outdoor Unit for more details.
- (e) Perform cold insulation work by insulating and taping the flare connection and reducer connection. Also insulate all the refrigerant pipes.

Apply Refrigerant Oil.

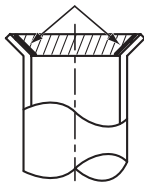

Two wrenches required to prevent damaging the copper piping.

Required Tightening Torque

Pipe Size	Tightening Torque
φ1/4 inch (6.35mm)	10.3 to 13.3 ft.lbs (14 to 18 N•m)
φ3/8 inch (9.52mm)	25.1 to 31.0 ft.lbs (34 to 42 N•m)
φ1/2 inch (12.7mm)	36.1 to 45.0 ft.lbs (49 to 61 N•m)
φ5/8 inch (15.88mm)	50.2 to 60.5 ft.lbs (68 to 82 N•m)
φ3/4 inch (19.05mm)	73.8 to 88.5 ft.lbs (100 to 120 N•m)

⚠ CAUTION

- Do not apply excessive force to the flare nut when tightening. Excessive force can result in the flare nut cracking and refrigerant leakage may occur. Use the specified tightening torque.
- For more details of the refrigerant piping work, vacuum pumping and refrigerant charge, refer to the Technical Manual for the Outdoor Unit.

5.2 Refrigerant Piping Work

Provide the refrigerant pipe in the field.

Make sure that the refrigerant pipe is connected to the same refrigerant cycle unit.

(1) Position of Piping Connection

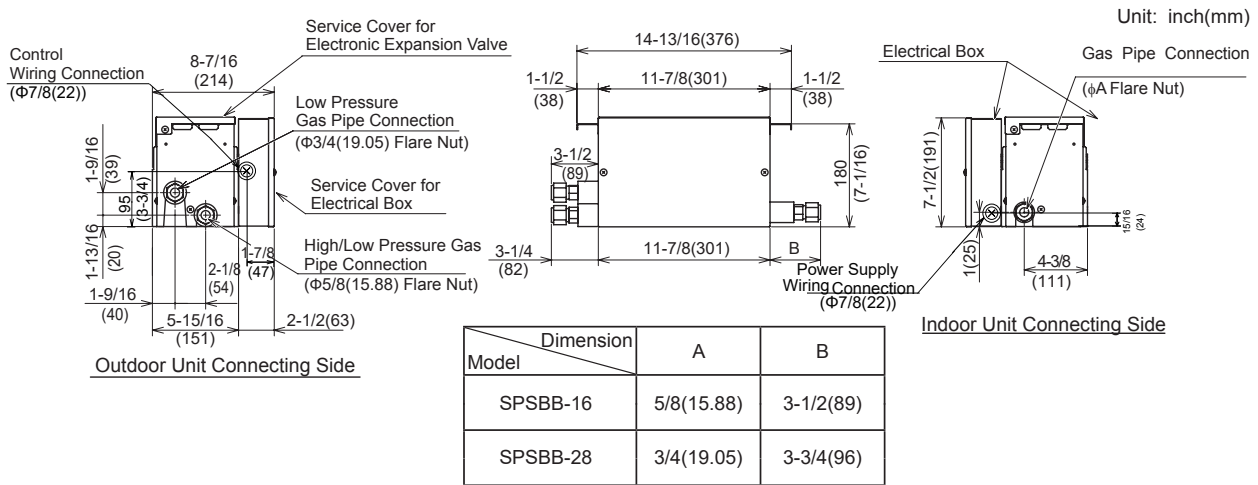

(2) Selecting Piping Size

- Select the size for the high/low pressure gas pipe, low pressure gas pipe and gas pipe according to the table 5.1. The size depends on the indoor unit total capacity connected downstream of the Switch Box .
- In case that the piping size from Table 5.1 and the piping connection size for Switch Box from Table 5.2 are different, use an accessory pipe according to the item 5.2(3).
- As for the BRANCH PIPE branch or header branch, refer to Technical Catalog for Outdoor Unit.

Table 5.1 Connected Indoor Unit Capacity and Piping Size

Unit: inch(mm)

Model	Connected Indoor Unit Capacity	Low Pressure Gas Pipe	High/Low Pressure Gas Pipe	Gas Pipe
SPSBB-16	14kBtu/h or less (4.3kW or less) (1.5HP or less)(1.2RT or less)	φ5/8(15.88)	φ1/2(12.7)	φ1/2(12.7) *
	14 to 38kBtu/h (4.3 to 11.2kW) (1.5 to 4.0HP)(1.2 to 3.2RT)	φ5/8(15.88)	φ1/2(12.7)	φ5/8(15.88)
	38 to 54kBtu/h(11.2 to 16kW) (4.0 to 6.0HP)(3.2 to 4.5RT)	φ3/4(19.05)	φ5/8(15.88)	φ5/8(15.88)
SPSBB-28	54 to 76kBtu/h(16 to 22.4kW) (6.0 to 8.0HP)(4.5 to 6.4RT)	φ3/4(19.05)	φ5/8(15.88)	φ3/4(19.05)
	76 to 96kBtu/h(22.4 to 28kW) (8.0 to 10.0HP)(6.4 to 8.0RT)	φ7/8(22.2)	φ3/4(19.05)	φ7/8(22.2)

*: In case that a branch is located downstream of the Switch Box and also the connected indoor unit capacity is 14kBtu/h (4.3kW,1.5HP,1.2RT) or less, use φ15.88 for the gas pipe.

Table 5.2 Piping Connection Size for Switch Box

Unit: inch(mm)

Model	Low Pressure Gas Pipe	High/Low Pressure Gas Pipe	Gas Pipe
SPSBB-16	φ3/4(19.05)	φ5/8(15.88)	φ5/8(15.88)
SPSBB-28	φ3/4(19.05)	φ5/8(15.88)	φ3/4(19.05)

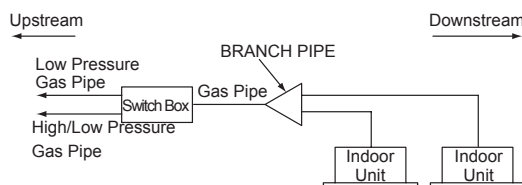

- Piping Work for Switch Box

Refrigerant piping size depends on the combinations with the outdoor unit. Refer to the installation and maintenance manual for the outdoor unit. Perform piping work for the Switch Box according to the following figure.

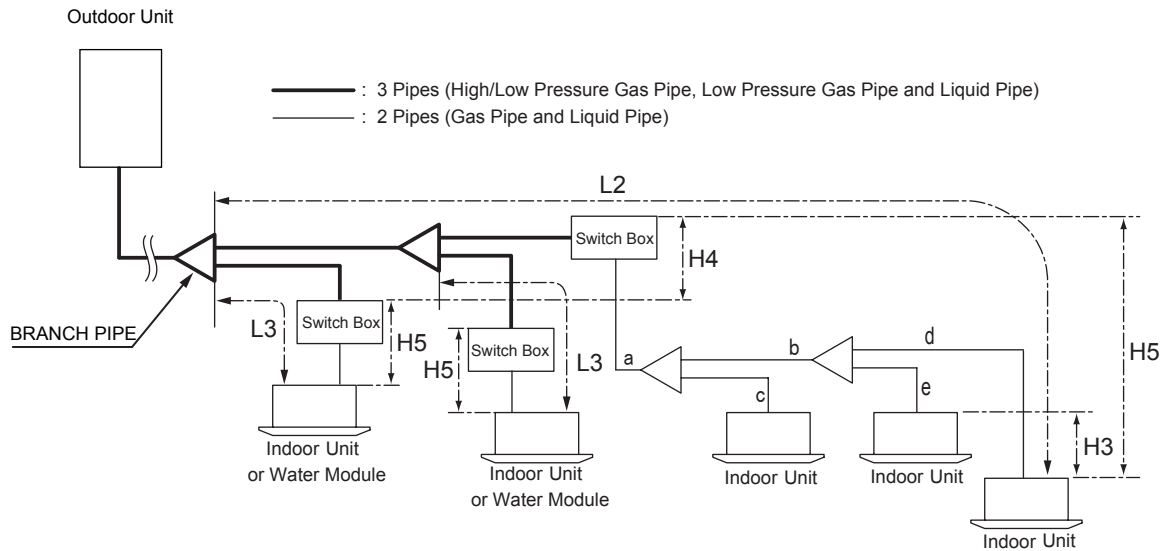

Item		Mark	Allowable Piping Length
Piping Length	Maximum Piping Length between BRANCH PIPE of 1st Branch and Terminal Indoor Unit	L2	≤ 295 ft (90m) ¹
	Maximum Piping Length between Each BRANCH PIPE and Each Indoor Unit	L3	≤ 131 ft (40m) ²
	In Case there is Branch after Switch Box, Total Piping Length from Switch Box to Each Connected Indoor Unit per Branch	a+b+c+d+e	≤ 131 ft (40m)
Height Difference	In Case there is Branch after Switch Box, Height Difference between Indoor Units Connected to Same Connection Port of Switch Box	H3	< 13 ft (4m)
	Height Difference between Switch Boxes	H4	< 49 ft (15m)
	Height Difference between Switch Box and Indoor Unit	H5	Refer to NOTE 3.

NOTES:

1. When the piping length from the first branch to the terminal indoor unit exceeds 131 ft (40m), there are restrictions. Refer to the installation and maintenance manual for the outdoor unit.
2. If the piping length (L3) between each BRANCH PIPE and indoor unit is considerably longer than other indoor unit, refrigerant may not flow well, and may lessen the unit's performance compared to other models. (Recommended Piping Length: Within 49 ft (15m))
3. Recommended height difference between Switch Box and indoor unit is within 49 ft (15m). If the height difference exceed this value, it may cause a decrease of operating performance.
4. Each Water Module must occupy one branch of Switch Box exclusively.

(3) Piping Connection

Perform the piping connection according to Table 5.1.

Unit: inch (mm)

Connected Indoor Unit Capacity: Q	SPSBB-16
$Q \leq 22\text{kBtu/h}$ $(Q \leq 6.3\text{kW})$ $(Q \leq 1.8\text{RT})$	
$22 < Q < 54\text{kBtu/h}$ $(6.3 < Q < 16.0\text{kW})$ $(1.8 < Q < 4.5\text{RT})$	
$Q = 54\text{kBtu/h}$ $(Q = 16.0\text{kW})$ $(Q = 4.5\text{RT})$	

Unit: inch (mm)

Connected Indoor Unit Capacity: Q	SPSBB-28
$54 < Q \leq 86\text{kBtu/h}$ $(16.0 < Q \leq 25.2\text{kW})$ $(4.5 < Q \leq 7.2\text{RT})$	
$86 < Q \leq 96\text{kBtu/h}$ $(25.2 < Q \leq 28.0\text{kW})$ $(7.2 < Q \leq 8.0\text{RT})$	

*1: Refer to the installation and maintenance manual for the outdoor unit for the following piping size.

- Upstream piping of Switch Box
- Downstream piping of Switch Box when the branch is located downstream of Switch Box.

*2: Refer to Section 5.1 for the flaring work.

NOTE:

The accessory numbers are listed in Table 4.1.

(4) Piping Insulation

Unit: inch(mm)

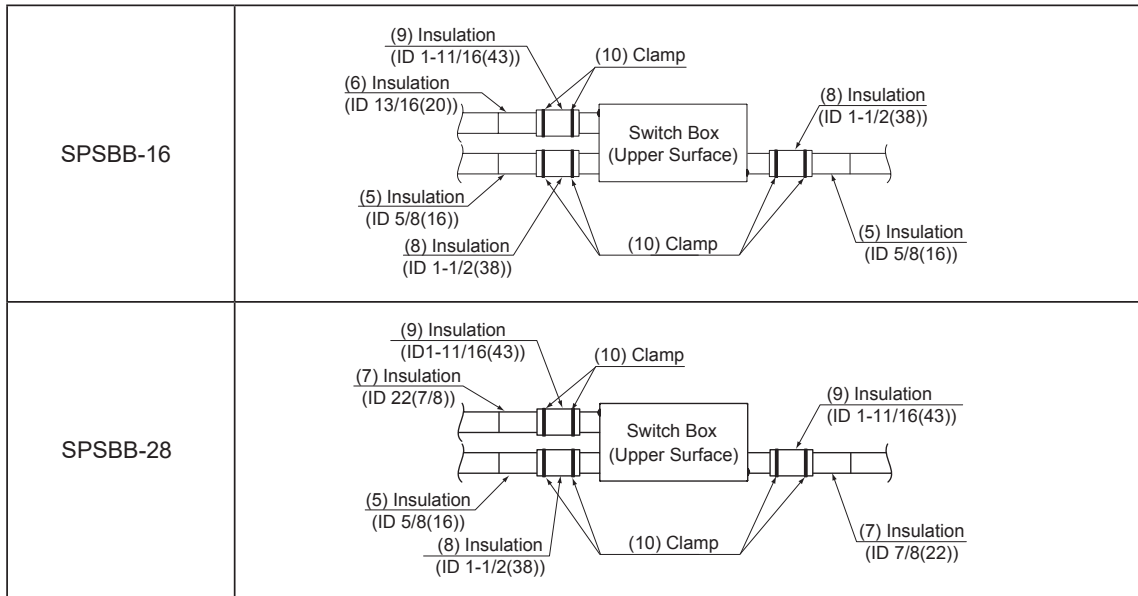

NOTES:

1. The accessory numbers are listed in Table 4.1.
2. When the humidity inside the ceiling is high, apply additional insulation to the flare nut connection. Refer to Table 4.1 for more details.

6. Electrical Wiring

WARNING

- **LOCK ALL ELECTRICAL POWER SUPPLY SWITCHES IN THE OFF POSITION BEFORE INSTALLING THE UNIT. FAILURE TO DISCONNECT POWER SUPPLY MAY RESULT IN ELECTRICAL SHOCK OR EVEN DEATH.**
- Turn off the main power switch to the Switch Box, the indoor unit and the outdoor unit before electrical wiring work or a periodical check is performed.
- Insulate electrical wiring, condensate piping, and electrical components from threats posed by burrowing animals and temperature extremes. Failure to do so can over time, deteriorate system performance.
- Secure the cables. External forces on the terminals could lead to a fire.
- Tighten screws according to the following torque.
M4: 0.7 to 1.0 ft.lbs (1.0 to 1.3 N•m) (TB1, TB2)
- The appliance shall be installed in accordance with national wiring regulations.

CAUTION

- Wrap the field-supplied insulation around the wires, and plug the wiring connection hole with the seal material to protect the product from any condensate water or insects.
- Tightly secure the wires with the cable clamp inside the Switch Box.
- Do not connect the ground wiring to the gas pipe, condensate pipe or lightening conductor.
Gas pipe: An explosion and ignition may occur when gas leaks.
Water pipe: There is no effect of ground wiring when a hard vinyl pipe is used.
Lightning conductor: The ground electric potential abnormally increases when a lightning conductor is used.

6.1 General Check

- (1) Make sure that the field-selected electrical components (main switches, fuses, ELB (Earth Leakage Breaker), wires, conduit connectors and wire terminals) are properly selected according to the electrical data indicated in Table 6.1. Make sure that the components comply with National Electrical Code (NEC).
- (2) Communication cable must be a minimum of 18-Gauge, 2-Conductor, Stranded Copper. Shielded cable must be considered for applications and routing in areas of high EMI and other sources of potentially excessive electrical noise to reduce the potential for communication errors. When shielded cabling is applied, proper bonding and termination of the cable shield is required as per Cooper & Hunter guidelines. Plenum and riser ratings for communication cables must be considered per application and local code requirements.
- (3) Use shielded communication cable for communication cable between the indoor and the outdoor unit (Max. 3,281 ft (1,000m)), and connect the shielded part to the ground screw in the electrical box.
- (4) Make sure that the power supply voltage is within $\pm 10\%$ of the rated voltage.
- (5) Check the capacity of the electrical wiring. If the power supply capacity is too low, the system cannot be started due to the voltage drop.
- (6) Make sure that the ground wiring is connected.

6.2 Electrical Wiring Connection

- (1) Perform the electrical wiring work for the Switch Boxes. Select the wire size according to the table below.
- (2) Pay attention to the marks on the terminal block when connecting wires for Switch Box and I.U./O.U. Refer to "Example of Electrical Wiring" for the wiring connection on the next page.

Table 6.1 Field Minimum Wire Sizes for Power Source

Model	Hz	Voltage	Voltage range	MCA	MOP	Power supply wiring size	Communication Cable Size
SPSBB-16 SPSBB-28	60	208/230V	Max.253V Min.187V	0.2	15	Wiring size and length must comply with local codes.	AWG18*1 (60.13AWG)

MCA: Minimum Circuit Ampacity (A)

MOP: Maximum Overcurrent Protective Device (A)

NOTES:

- (1) Use a shielded cable for the transmitting circuit and connect it to ground.
- (2) Field wiring shall be in conformity to local laws and regulations, and all wiring operations must be performed by qualified professionals.
- (3) Once the power cord is damaged, the dealer or the professionals from designated maintenance department must be contacted in a timely manner for repair and replacement.

6.3 Electrical Wiring

The electrical wiring connection for the Switch Box is shown in Figure 6.1.

- (1) Turn OFF the main power switch and take off the electrical box cover of Switch Box .
- (2) Connect the power supply wiring to L1 and L2 on the terminal block TB1, and connect ground wiring to the terminals in the electrical box.
- (3) Connect the communication cable to “1”, “2”, “3” and “4” on the terminal block TB2 mounted on PCB1.
- (4) Tightly clamp the wires using the cable clamp inside the electrical box.
- (5) Attach the electrical box cover after completing the wiring work.

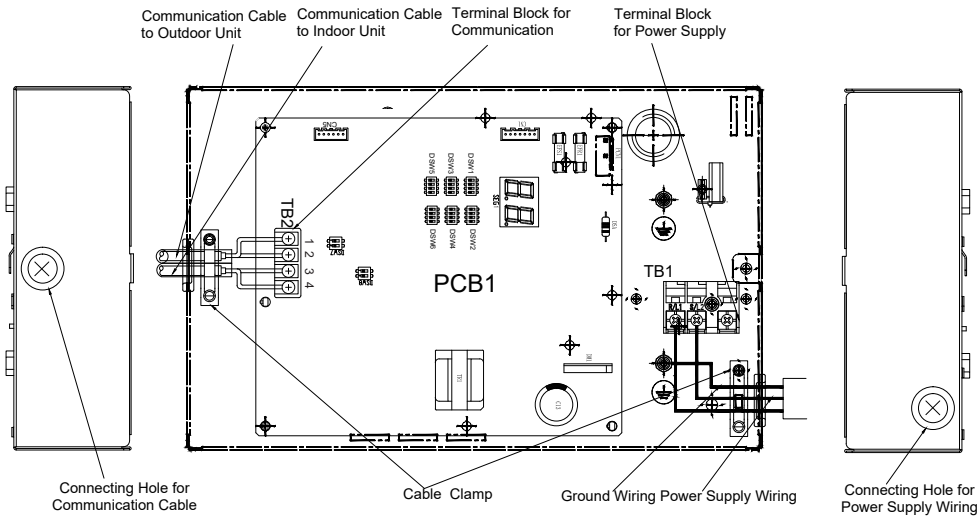

NOTE:

The accessory numbers are listed in Table 4.1.

Figure 6.1 Electrical Wiring Connection

- Example of Electrical Wiring

The following figure shows an example of electrical wiring around the Switch Boxes.

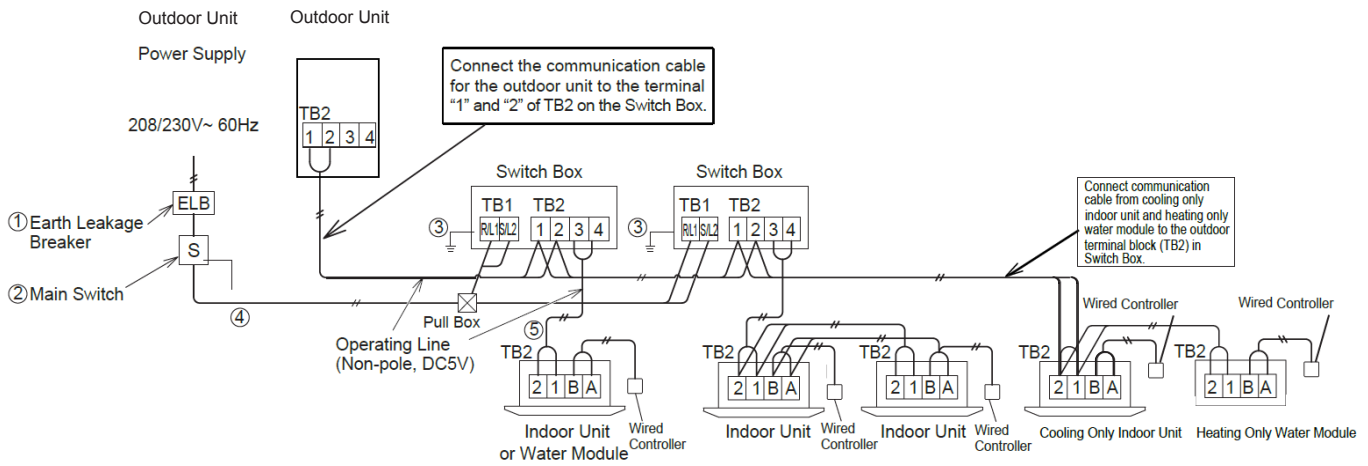

(In case that the multiple indoor units are connected to the same Switch Box, the operation mode (cooling/heating) for the indoor units will be the same.

NOTES:

1. Do not apply excessive voltage to the communication cable DC5V (non-polarity) between the outdoor unit and the Switch Box , between the Switch Box and the indoor unit or between Switch Boxes.
2. Use 2-Conductor shielded communication cable for the communication cable. (Do not use 3-Conductor cable or over.)
3. Connect the communication cable for the outdoor unit to terminals “1” and “2” on TB2 in the Switch Box.
4. Connect the communication cable for the cooling only indoor unit or heating only water module to the terminal “1” and “2” on TB2 in the Switch Box.
5. For a Switch Box in the same refrigerant cycle, an electrical power supply can be supplied by one main switch.
6. Do not connect the power supply line (208/230V) to the terminal block for communication cable.
7. Connect the ground wiring for the outdoor/indoor units and Switch Box. When ground resistance is less than 100 ohms, ground wiring work should be performed by the qualified electrician.
8. Do not run the communication cables along with power supply wiring in the Switch Box.
Separate communication cables from the power supply wirings.

6.4 Setting of DIP Switches

DSWs for the Switch Box SPSBB-16 and SPSBB-28 are set as shown below .

TURN OFF the power supply before adjusting DIP switch settings. Otherwise, the settings will be invalid and not take effect.

- Setting before shipping

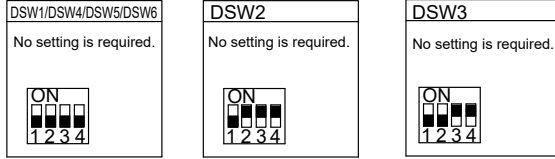

- Setting of forced opening of MVS and MVD. Setting on DSW1

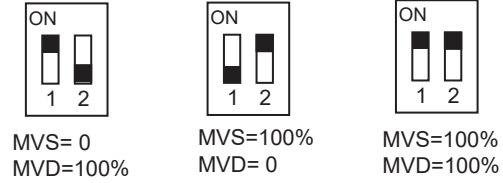

- Fuse Recovery

In case of applying high voltage to terminals of TB2, the 0.5A fuse on the PCB is cut. In such a case, first reconnect the wiring correctly to the terminal block, and then set the pin to ON.

- DSW8(for TB2-1/2)



Factory Setting Fuse Recovery

- DSW7(for TB2-3/4)



Factory Setting Fuse Recovery

NOTICE

All indoor and outdoor units must be shut down prior to attempting to make DIP Switch adjustments, otherwise, the settings will not take effect.

NOTE

The “■” mark indicates the position of DIP switches. Figures show setting before shipment.

7. Test Run

NOTICE

Refrigerant piping and connecting wires should be connected to the same refrigerant cycle system. If they are connected to the dissimilar refrigerant cycle systems, a malfunction may occur.

! WARNING

- **Special Attention Regarding Refrigerant Gas Leakage**

The refrigerant R410A is non-toxic and inflammable in its original state.

However, in consideration of a state where the refrigerant leaks into the room, measures against refrigerant leaks must be taken in small rooms where the tolerable level could be exceeded.

Take countermeasures by installing ventilation devices, etc.

< Calculation of Refrigerant Concentration >

- (1) Calculate the total quantity of refrigerant R (lbs) charged in the system connecting all the indoor units of rooms to be air-conditioned.
- (2) Calculate the room Volume V (cuft) of each room.
- (3) Calculate the refrigerant concentration C (lbs/cuft) of the room according to the following equation.

$$\frac{R: \text{Total Quantity of Charged Refrigerant (lbs)}}{V: \text{Room Volume (cuft)}} = C: \text{Refrigerant Concentration} \leq 0.93 \text{ (lbs/cuft) for R410A}$$

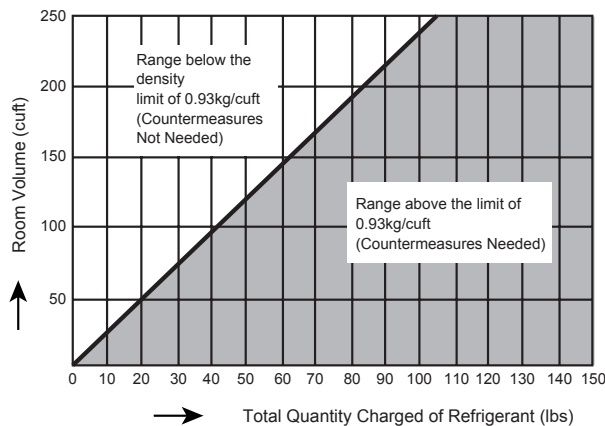

Perform a test run according to the "Installation and Maintenance Manual" of the outdoor unit.

! WARNING

- **Do not operate the system until all the check points are cleared.**
 - (A) Check to ensure that the electrical resistance is more than 1 megohm by measuring the resistance between ground and the terminal block in the electrical box. If not, do not operate the system until the electrical leakage is found and repaired.
 - (B) Check to ensure that the stop valves of the outdoor unit are fully opened, and then start the system.
 - (C) Apply power to the outdoor unit(s) at least 12 hours prior to operation of the system for preheating of the compressor oil.
- **Pay attention to the following items while the system is running.**
 - (A) Do not touch any of the parts by hand at the discharge gas side, since the compressor chamber and the pipes at the discharge side are heated higher than 194°F (90°C).

8. Safety and Control Device Setting

Switch Box

Model		SPSBB-16, SPSBB-28
For Control Circuit Fuse	A	3.15
