

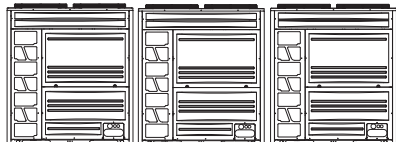

VRF AIR-CONDITIONER (HEAT RECOVERY)

Installation Manual

Outdoor Unit

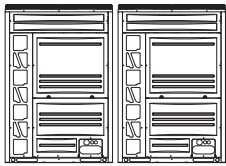
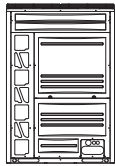

Basic Units:

CHV6-072URB
CHV6-096URB
CHV6-120URB
CHV6-144URB
CHV6-168URB
CHV6-192URB

Combination

Modules:
CHV6-216~456URB

IMPORTANT:

THANK YOU FOR PURCHASING THIS CENTRAL AIR
CONDITIONERS. READ AND UNDERSTAND THIS
MANUAL BEFORE USING THE AIR CONDITIONERS.
KEEP THIS MANUAL FOR FUTURE REFERENCE.

Dear user:

Thank you for choosing and using our products. For your better understanding and use of this product, be sure to read and comply with the following related matters before use.

IMPORTANT NOTICE

Signal words (DANGER, WARNING and CAUTION) are used to identify levels of hazard seriousness.

Definitions for identifying hazard levels are provided below with their respective signal words:



: DANGER indicates a hazardous situation which, if not avoided, will result in death or serious injury.



: WARNING indicates a hazardous situation which, if not avoided, could result in death or serious injury.



: CAUTION, used with the safety alert symbol, indicates a hazardous situation which, if not avoided, could result in minor or moderate injury.

NOTE : NOTE is useful information for operation and/or maintenance.

- This manual should be considered as a permanent part of the air conditioning equipment and should remain with the air conditioning equipment.
- This manual gives a common description and information for this air conditioner which you operate as well for other models. Our company pursues a policy of continuing improvement in design and performance of products. The right is therefore reserved to vary specifications without notice.
- Our company cannot anticipate every possible circumstance that might involve a potential hazard. This air conditioner is designed for standard air conditioning only. Do not use this heat recovery air conditioner for other purposes such as drying clothes, refrigerating foods or for any other cooling or heating process. Do not install the unit in the following places. It may cause a fire, deformation, corrosion or failure.
 - * Places where oil (including machinery oil) sprays
 - * Places where a lot of sulfide gas drifts such as a hot spring.
 - * Places where flammable gas may generate or flow.
 - * Places where strong salty wind blows such as coast regions , or places with high acidity or alkalinity.
- Do not install the unit in the place where silicon gas drifts. If the silicon gas attaches to the surface of heat exchanger, the fin surface repels water. As a result, drain water splashes outside of the drain pan and splashed water runs inside of electrical box. In the end, water leakage or electrical devices failure may occur.
- Do not install the unit in the place where the breeze directly catches the animals and plants. It could adversely affect the animals and plants.
- Installation and service engineering must comply with local standards, laws and regulations.
- As the "public inaccessible appliances", the indoor units are required to be installed at a height of no lower than 8.2ft.(2.5m).
- The installation of the air conditioner can only be carried out by dealer or professional, and self installation by user may cause water leakage, electric shock or a fire.
- If you have any questions, contact your dealer or designated service center of our company.
- To protect the environment, please do not discard the product at will, and our company can provide recycling services in accordance with the relevant provisions of the country and provide replaceable parts in accordance with national standard requirements.
- This air conditioner has been designed for the following temperatures. Operate the air conditioner within this range.

Temperature

°F(°C)

DX Indoor Unit			Maximum	Minimum
Cooling Operation	Indoor	°F DB/°F WB (°C DB/°C WB)	89/73 (32/23)	69/59 (21/15)
	Outdoor	°F DB (°C DB)	126 (52)*	14 (-10)
Heating Operation	Indoor	°F DB (°C DB)	80 (27)	59 (15)
	Outdoor	°F WB (°C WB)	62 (16.5)	-13 (-25)**

Water Module			Maximum	Minimum
Cooling Operation	Water Inlet	°F (°C)	77 (25)	50 (10)
	Outdoor	°F DB (°C DB)	118 (48)	50 (10)
Heating Operation	Water Inlet	°F (°C)	130 (54)	50 (10)
	Outdoor	°F WB (°C DB)	110 (43)	-13 (-25)**

DB : Dry Bulb, WB : Wet Bulb

NOTES:

(*) 118 °F(48°C)DB ~ 126°F(52°C) DB, Operation Control Range

(**) -4°F(-20°C) WB ~-13°F (-25°C) WB, Operation Control Range



DANGER

- Do not perform installation work, refrigerant piping work, drain pump, drain piping and electrical wiring connection without referring to our installation manual. If the instructions are not followed, it may result in a water leakage, electric shock or a fire. In case of a fire, cut off the power immediately; do not touch the electrical parts by hand to avoid electric shock hazard. These products are equipped with electrical parts. Do not pour water into the indoor or outdoor unit. Otherwise, it will cause a serious electrical failures.
- Do not open the service cover of the indoor or outdoor units without turning OFF the main power supply, otherwise it may cause a serious safety accident. (In any case, users of the equipment are not allowed to open the service cover).
- Do not touch or adjust safety devices inside the indoor unit or outdoor units. If these devices are touched or readjusted, it may cause a serious accident.
- Refrigerant R410A for this unit is incombustible, non-toxic and odorless; however if the refrigerant is leaked and is contacted with fire, toxic gas will generate. Also because the R410A is heavier than air, the floor surface will be filled with it, which could cause difficulty with breathing due to insufficient air. Turn OFF the main switch, extinguish any naked flames and contact your service contractor, if refrigerant leakage occurs. Do not charge oxygen, acetylene or other flammable and poisonous gases into the refrigerant cycle when performing a leakage test or an air-tight test. These types of gases can cause an explosion. It is recommended that nitrogen be used for these types of tests.
- Refrigerant safety leakage standards for construction and operation systems are determined in accordance with local regulations or standards.
- Use an ELB (Earth Leakage Breaker, with an actuation time of 0.1 second or less) at or above medium induction speed, otherwise it may cause an electric shock or a fire.
- For installation, firmly connect the refrigerant pipe before the compressor starts operating.
- For maintenance, relocation and disposal, remove the refrigerant pipe after the compressor stops.
- Do not perform a short-circuit of the protection device such as a pressure switch when operating. It may cause a fire and explosion.



WARNING

- Do not use any sprays such as insecticide, lacquer, hair spray or other flammable gases within approximately 3.28ft.(1m) from the system.
- If circuit breaker is often activated, stop the system and contact your dealer or service contractor. Check that the ground wire is securely connected. If the unit is not correctly grounded, it leads electric shock. Do not connect the ground wiring to gas piping, water piping, lighting conductor or ground wiring for telephone.
- Before performing any brazing work, check to ensure that there is no flammable material around. When charging refrigerant be sure to wear leather gloves to prevent cold injuries.
- Protect the wires, electrical parts, etc. from rats or other small animals. If not protected, rats may gnaw at unprotected parts and which may lead to a fire.
- Fix the cables securely. External forces on the terminals could lead to a fire.
- Provide a sufficiently strong foundation. If not, the unit may fall down and it may lead to injuries.
- Perform electrical work according to Installation Manual and all the relevant regulation and standards.
- If the instructions are not followed, an electrical failure and fire may occur due to insufficient capacity and inadequate performance. Use specified cables between units and choose the cables correctly. If not, an electrical failure or a fire may break out.
- Ensure that the outdoor unit is not covered with ice and snow before use.
- This appliance can be used by children aged from 8 years and above and persons with reduced physical, sensory or mental capabilities or lack of experience and knowledge if they have been given supervision or instruction concerning use of the appliance in a safe way and understand the hazards involved. Children shall not be made by children without supervision.
- The A-weighted emission sound pressure level at workstations does not exceed 70 dB(A).
- Cancer and reproductive harm-www.P65Warnings.ca.gov.
- Take measures to ensure that the refrigerant limitations in ASHRAE Standard 15 (Canada: B52) or other local codes, are followed. If refrigerant gas has leaked during the installation work, ventilate the room immediately.



CAUTION

- Do not step on or put any objects on the product.
- Do not put any foreign matters on the unit or inside the unit.
- Do not install the indoor unit, outdoor unit, remote control switch and cable within approximately 9.8ft.(3m) from strong electromagnetic wave radiators such as medical equipment.
- Starting the unit after longtime idleness requires the compressor temperature to meet the starting requirements or reach a certain heating time.

NOTE:

- It is recommended to ventilate the room every 3 to 4 hours.
- In some cases, the air conditioner may not operate properly under the following cases.
 - * In case the power supplied by the power transformer is less than or equal to the electric power of the air conditioner.
 - * In case the large power-consuming equipment is too close to the power supply wiring for the air conditioner, so that large surge voltage may be inducted in the power supply wiring of the air conditioner.
- The heating capacity of the outdoor is decreased according to the air temperature. Therefore, it is recommended that auxiliary equipment be used in the field when the unit is installed in a low temperature region.
- The repair and maintenance of this air conditioner can only be carried out by the professionals.

CHECKING PRODUCT RECEIVED

- Upon receiving this product, inspect it for any shipping damage. Claims for damage in a written form, either apparent or concealed, should be filed immediately with the shipping company.
- Check the model number, electrical characteristics (power supply, voltage and frequency) and accessories to determine if they are correct. The standard utilization of the unit shall be explained in these instructions. Please contact your local agent, as the occasion arises.

Our company's liability shall not cover defects arising from the alteration performed by a customer without our company's consent in a written form.

TABLE OF CONTENTS

1. Structure	1
1.1 Outdoor Unit & Refrigerant Cycle	1
1.2 Necessary Tools and Instrument List for Installation	1
2. Before Installation	2
3. Transportation and Handling	4
3.1 Transportation	4
3.2 Handling Method	5
4. Outdoor Unit Installation	6
4.1 Accessories Factory-Supplied	6
4.2 Installation environment	6
4.3 Foundation	7
4.4 Drainage	8
5. Refrigerant Piping Work	11
5.1 Piping Materials	11
5.2 Flaring and Joint	12
5.3 Caution about Outdoor Unit Installation	13
5.4 Piping Connection for System	15
6. Electrical Wiring	19
6.1 General Check	19
6.2 Electrical Wiring	20
6.3 Electrical Wiring Connection	21
6.4 Electrical Wiring Connection of The System	22
6.5 DIP Switch Setting of Outdoor Unit	25
7. Additional Refrigerant Charge	28
7.1 Air-Tight Test	28
7.2 Vacuuming	29
7.3 Charging Operation	30
8. Test Run	31
8.1 Before Test Run	31
8.2 Test Run	32

1. Structure

1.1 Outdoor Unit & Refrigerant Cycle

Regarding structure drawings and refrigerant cycle diagram, please refer to Technical Catalogue.

1.2 Necessary Tools and Instrument List for Installation

The design pressure for this product is 601psi(4.15MPa).

To avoid accidental mixing of the different refrigerant or different refrigerant oil, the sizes of the charging connections have been changed. It is necessary to prepare the following tools before performing installation.

No.	Tool	No.	Tool	No.	Tool	No.	Tool
1	Handsaw	6	Copper Pipe Bender	11	Spanner	16	Leveller
2	Phillips Screwdriver	7	Plier	12	Charging Cylinder	17	Clamper for Solderless Terminals
3	Vacuum Pump	8	Pipe Cutter	13	Control Valve	18	Hoist (for Indoor Unit)
4	Refrigerant Gas Hose	9	Brazing Kit	14	Cutter for Wires	19	Ammeter
5	Megohmmeter	10	Hexagon Wrench	15	Gas Leak Detector	20	Voltage Meter

Note: Use tools and measuring instruments exclusively for the new refrigerant R410A in case of direct contact with the refrigerant.



The pressure of refrigerant R410A is 1.4 times higher than that of conventional refrigerant, impurities such as moisture, oxide film, and grease affect R410A easily. Be sure to remove any moisture, dust, different refrigerant or refrigeration oil from the refrigerant cycle. Otherwise, it may lead to explosion, injury, leakage, electric shock or a fire.

○ : interchangeable with current R22
 × : Prohibited

■ : only for Refrigerant R410A (not interchangeable with R22)
 ● : only for Refrigerant R407C (not interchangeable with R22)

Measuring Instrument and Tool		Interchangeability with R22		Reason of Non-Interchangeability and Attention (★: Strictly Required)	Application
		R407C	R410A		
Refrigerant Pipe	Pipe Cutter Chamfering Reamer	○	○	—	Cutting Pipe Removing Burrs
	Flaring Tool	○	○■	* R410A requires high pressure resistance piping and larger flaring. In case of material 1/2H, flaring is not available.(The flaring tools for R410A are applicable to R407C)	Flaring for Tubes
	Extrusion - Adjustment Gauge	-	■		Dimensional Control of Tube after Flaring
	Pipe Bender	○	○	* In case of material 1/2H, bending is not available. Use elbow for bend and braze.	Bending
	Expanding Tool	○	○	* In case of material 1/2H, expanding of tube is not available. Use joint for connecting tube.	Expanding Tubes
	Torque Wrench	○	■	* For Φ1/2in., Φ5/8in. of R410A, spanner size is up to 5/64in.	Connection of Flare Nut
			○	* For Φ1/4in., Φ3/8., Φ3/4in., spanner size is the same.	
	Brazing Tool	○	○	* Perform brazing work properly (adjustable flame and heating method, filler applicable)	Brazing for Tubes
	Nitrogen Gas	○	○	* Strict control against contamination (Blow nitrogen during brazing.)	Prevention from Oxidation during Brazing Air-tight test
Lubrication Oil (for Flare Surface)	●	■	* Use a synthetic oil which is equivalent to the oil used in the refrigerant cycle. * Synthetic oil absorbs moisture quickly.	Applying Oil to the Flared Surface	
Refrigerant Charge Vacuum Drying	Refrigerant Cylinder	●	■	* Check the cylinder for the corresponding refrigerant. ★Liquid refrigerant charging is required regarding zeotropic refrigerant.	Refrigerant Charging
	Vacuum Pump	○	○	★The current pumps are applicable. However, it is required to mount a vacuum pump adapter which can prevent reverse flow when a vacuum pump stops, resulting in no reverse oil flow.	Vacuum Pumping
	Adapter for Vacuum Pump Reverse Flow prevention	●	※■		
	Control Valve	●	■	* No interchangeability is available due to higher pressures when compared with R22. Connection diameter is different: R410A: UNF1/2, R407C: UNF7/16	Vacuum Pumping, Vacuum Holding, Refrigerant Charging and Check of Pressures
	Charging Hose	●	■	★Do not use old ones to the different refrigerant. Otherwise, mineral oil will flow into the cycle and cause sludges, resulting in clogging or compressor failure.	
	Charging Cylinder	×	×	* Use the weight scale when charging	Refrigerant Charging
	Weight Scale	○	○	—	Measure refrigerant quantity
	Refrigerant Gas Leakage Detector	●	※■	* The current gas leakage detector (R22) is not applicable due to different detecting method.	Refrigerant Charging Gas Leakage Check
Interchangeable with R410A					

※ interchangeable with R407C

2.Before Installation

Line-Up of Outdoor Unit

【Basic Unit】

Capacity kBtu/h(RT)	(6RT)	96(8RT)	120(10RT)	144(12RT)	168(14RT)
Model	CHV6-072URB	CHV6-096URB	CHV6-120URB	CHV6-144URB	CHV6-168URB

Capacity kBtu/h(RT)	192(16RT)
Model	CHV6-192URB

【Combination Module】※

Capacity kBtu/h(RT)	216(18RT)	240(20RT)	264(22RT)	288(24RT)	312(26RT)
Model	CHV6-216URB	CHV6-240URB	CHV6-264URB	CHV6-288URB	CHV6-312URB
Combination	CHV6-120URB	CHV6-120URB	CHV6-144URB	CHV6-144URB	CHV6-168URB
	CHV6-096URB	CHV6-120URB	CHV6-120URB	CHV6-144URB	CHV6-144URB

Capacity kBtu/h(RT)	336(28RT)	360(30RT)	384(32RT)
Model	CHV6-336URB	CHV6-360URB	CHV6-384URB
Combination	CHV6-168URB	CHV6-192URB	CHV6-192URB
	CHV6-168URB	CHV6-168URB	CHV6-192URB

Capacity kBtu/h(RT)	408(34RT)	432(36RT)	456(38RT)
Model	CHV6-408URB	CHV6-432URB	CHV6-456URB
Combination	CHV6-144URB	CHV6-144URB	CHV6-168URB
	CHV6-144URB	CHV6-144URB	CHV6-144URB
	CHV6-120URB	CHV6-144URB	CHV6-144URB

3. Transportation and Handling

3.1 Transportation

Transport the product as close to the installation location as practical before unpacking. When using a crane, hang the unit according to the description on the label attached to the outdoor unit.

⚠ DANGER

Do not hang the unit by the ropes at the wooden pallet.

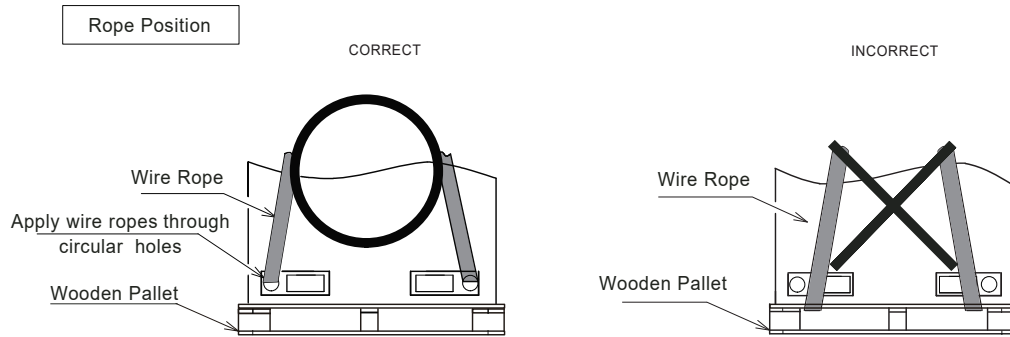

⚠ CAUTION

1. Transportation and Storage

Due to the limited strength of corrugated paper frame, pay attention to the followings in order to prevent the product from deformation.

- Do not step on or put any objects on the product.
- Apply two lifting wires onto the outdoor unit, when lifting by crane.
- Do not stack the product when storing.

2. Transportation and Wire Rope

- To protect the unit, do not remove any packing.
- Do not stack or put any objects on the product.
- Apply wire ropes on the both side of the unit as shown in the figure.

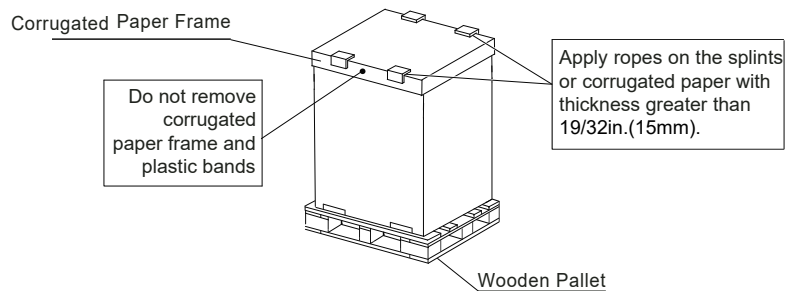

3.2 Hanging Method

When hanging the unit, ensure a balance of the unit, check to ensure safety and lift up smoothly.

- (1) Do not remove any packing materials.
- (2) Hang the unit in packaged state with two wire ropes, as shown in Fig. 3.1.

Fig. 3.1 Hanging Work for Transportation

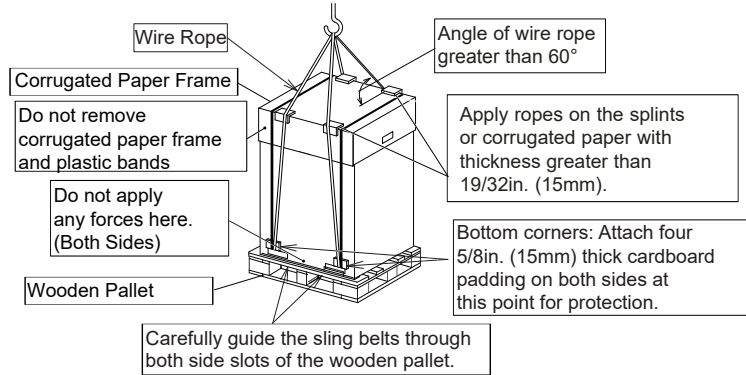

- (3) Hang the unit without wooden pallet, as shown in Fig.3.2.

Fig. 3.2 Hanging Work without Wooden Pallet

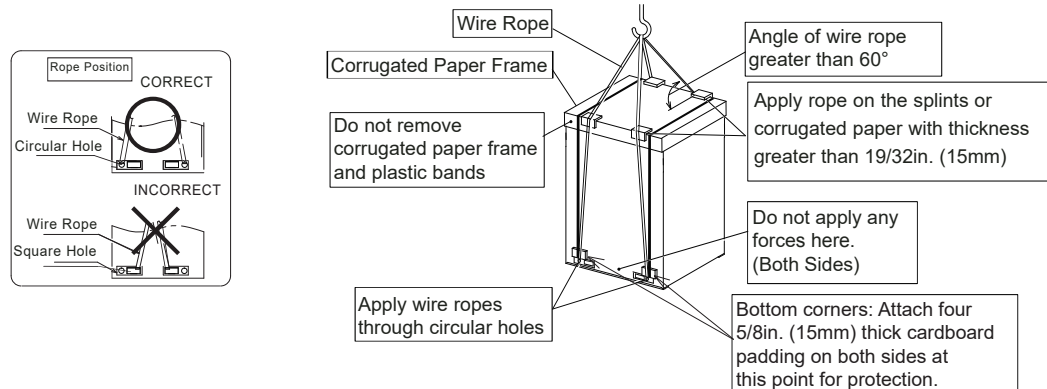

Do not apply excessive force on the square holes with forks or other materials. The bottom of the unit may be deformed.

- *Do not push the bottom base by fork.
- *Do not use roller.

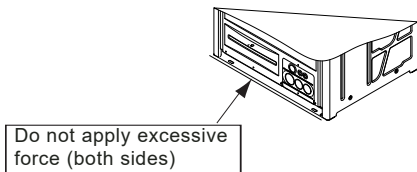

NOTE

In case of transportation after unpacking, protect the unit with splints or cloth.

⚠ WARNING

Check to ensure that no foreign matters left in the outdoor unit before installation and test run. Otherwise, a fire, failure or personal injury, etc. may occur.































4. Outdoor Unit Installation

4.1 Factory-Supplied Accessories

Check to ensure that the following accessories are packed with the outdoor unit.

Table 4.1 Factory-Supplied Accessories

unit:in.(mm)

Accessory	72	96	120	144	168	192
Accessory pipe pouch	 x1	 x1	 x1	 x1	 x1	 x1
Electrical accessory pouch	 x1	 x1	 x1	 x1	 x1	 x1
Fastener pouch	 x1	 x1	 x1	 x1	 x1	 x1
Screw (Spare)	 x3	 x3	 x3	 x3	 x3	 x3
Installation Manual						

NOTE:

If any of these accessories are not packed with the unit, please contact your contractor.

4.2 Installation

- (1) Install the outdoor unit in a dry well ventilated environment.
- (2) Install the outdoor unit where it is in the shade or a place where not be exposed to direct sunshine or direct radiation from high temperature heat source.
- (3) Install the outdoor unit where the sound or the discharge air from the outdoor unit does not affect neighbors or surrounding ventilation.
The operating sound at the rear or right/left side is 3 to 6dB(A) higher than the value in the catalog at the front side.
- (4) Install the outdoor unit in a space with limited access to general public.
- (5) Check to ensure that the foundation is flat, level and sufficiently strong.
- (6) Do not install the outdoor unit where dust or other contamination could block the outdoor heat exchanger.
- (7) When installing the outdoor unit in snow-covered areas, mount the field-supplied hoods on the top of the outdoor unit and the inlet side of the heat exchanger.
- (8) In heating or defrosting operation, drain water is discharged. Provide adequate drainage around the foundation. If installing the unit on a roof or a veranda, avoid draining in or over walkways to prevent water dripping on people or the formation of ice in winter. In case of installing such a place, provide the additional drainage around the foundation.
- (9) Do not install the outdoor unit in a space where a seasonal wind directly blows to the outdoor heat exchanger or a wind from a building space directly blows to the outdoor fan.

NOTES:

1. Do not install the outdoor unit where there is a high level of oil mist, flammable gases, salty air or harmful gases such as sulphur and an acid or alkaline environment.
2. Do not install the outdoor unit where the electromagnetic wave is directly radiated to the electrical control box.
3. Install the outdoor unit as far as possible, at least 9.8ft.(3m) from the electromagnetic wave radiator.

4.3 Foundation

●Concrete Foundations

- (1) The height of the foundation should be 5-29/32in.(150mm) higher than the ground level.
- (2) Provide a drainage ditch around foundation for smooth drain.

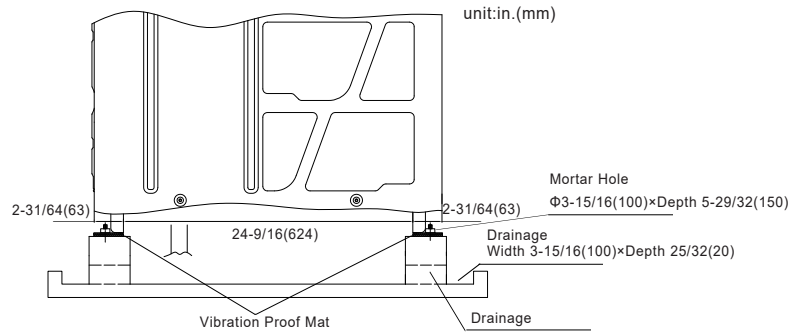

*Provide concrete foundation as shown in the figure.

*Do not provide concrete foundation as shown below.
The foot of the outdoor unit may be deformed.

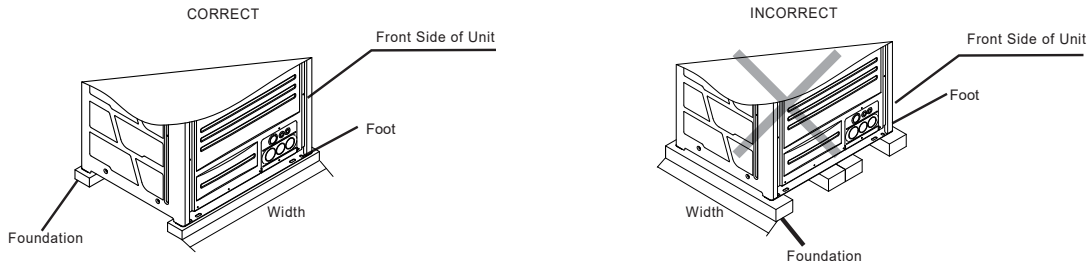

- (3) Install the outdoor unit in the front-rear and right-left direction horizontally with a level gauge. Check to ensure that the gradient in four directions (front, rear, right and left) is within 24/64in.(10mm).

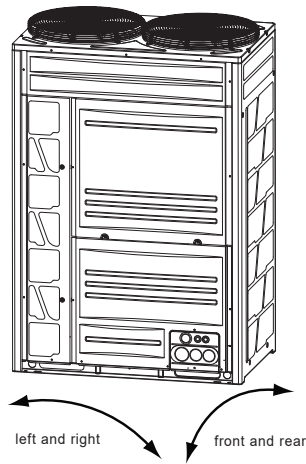

- (4) Provide a strong and correct foundation so that:
 - a. the outdoor unit is not on an incline.
 - b. no abnormal sound.
 - c. the outdoor unit will not fall down due to a strong wind or earthquake.

(5) When installing the outdoor unit, fix the unit by anchor bolts (field-supplied).

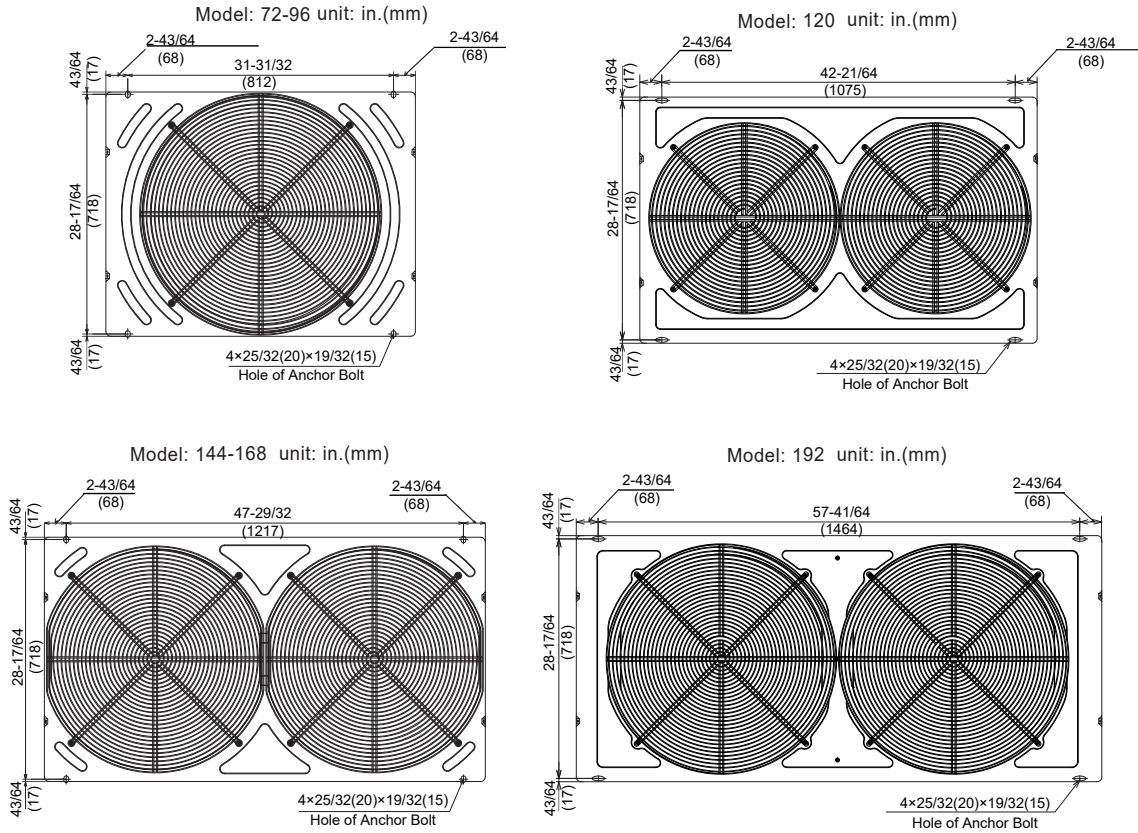

Secure the outdoor unit with the anchor bolts.

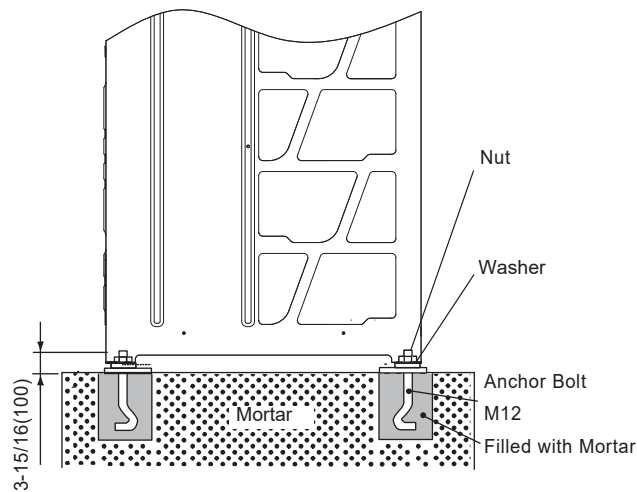

4.4 Drainage

Drainage is discharged during heating and defrosting operation, and so is rain water. Pay attention to the following:

- (1) Choose a place where well drainage is available, or provide a drain ditch.

- (2) Do not install the unit over the walkways. Condensate may fall on people.
In case of installing the unit in such a place, provide the additional drain pan.
- (3) When drain piping is necessary for the outdoor unit, use the drain boss set (Optional, DC-01Q).
Do not use drain boss and drain pan kit in the cold area. The drain water in the drain pipe may be frozen and then crack the drain pipe.
- (4) When installing the unit on a roof or a veranda, drain water sometimes turns to ice on a cold morning.
Therefore, avoid draining into an area where people often use because it is slippery.

Model: 72-96 unit: in.(mm)

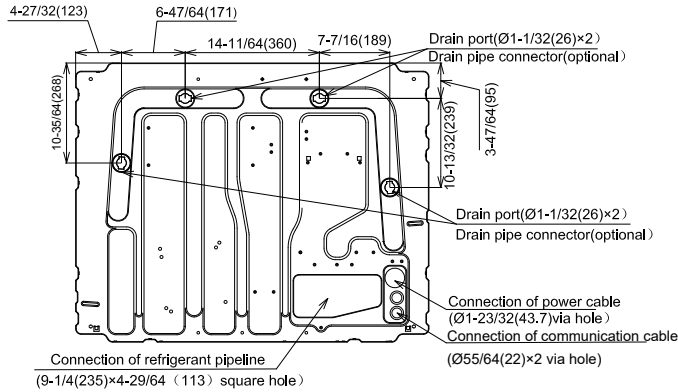

Model: 120 unit: in.(mm)

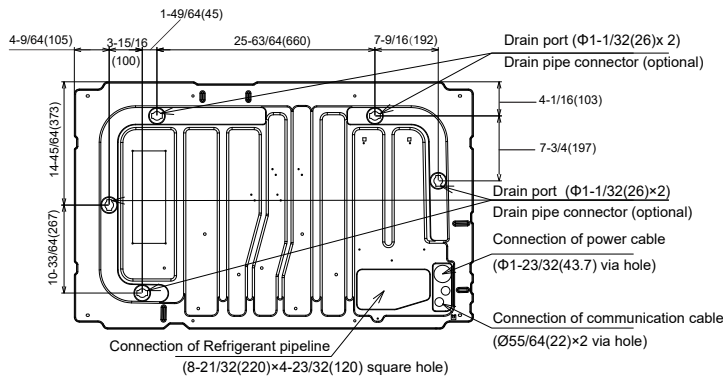

Model: 144-168 unit: in.(mm)

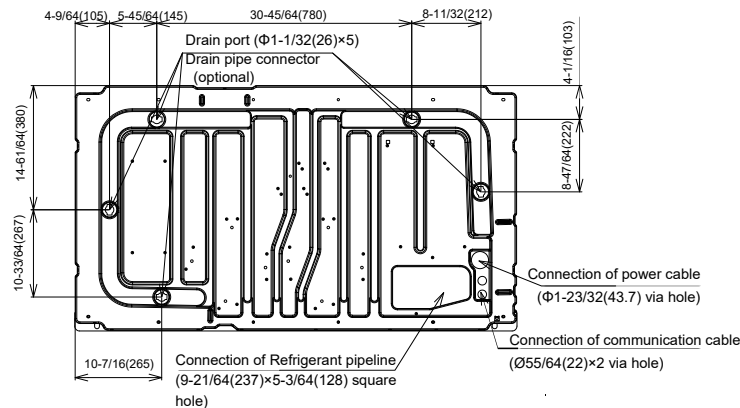

Model: 192

unit: in.(mm)

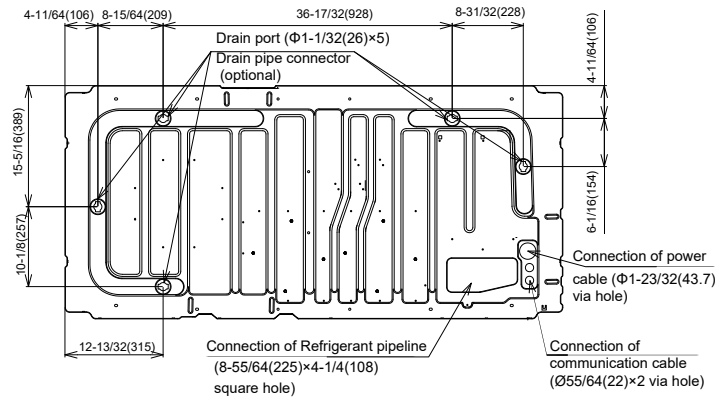

● Drain Boss (Optional Parts)

The drain boss is for the drain pipe connection in order to use outdoor unit bottom base as a drain pan.

Name	Model
Drain Boss	DC-01Q

Component Formation of Drain Boss

Model	Parts Name	Q'ty	Application
DC-01Q	Drain Boss	1	Connecting for Drain Piping
	Drain Cap	1	Embolization for Drain Hole
	Rubber Cap	4	Sealing for Boss and Cap

Installation Position

Example: Model 72

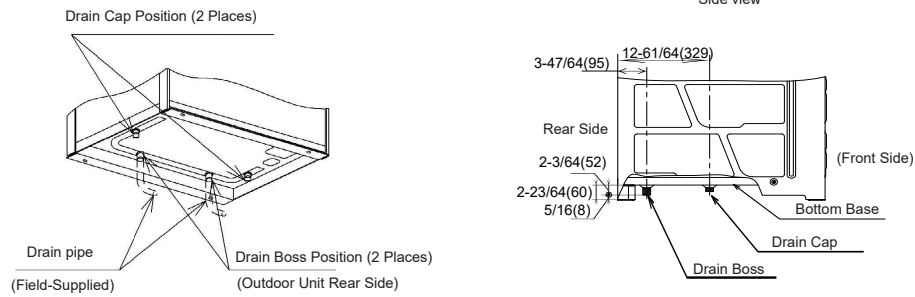

5.Refrigerant Piping Work

DANGER

- Use refrigerant R410A in the refrigerant cycle.
Do not charge oxygen, acetylene or other flammable and poisonous gases into the refrigerant cycle when performing a leakage test or an air-tight test. These types of gases are extremely dangerous and can cause an explosion. It is recommended that compressed air, nitrogen be used for these types of tests.
- Check to ensure that no pressure exists inside the stop valve before removing the flange

CAUTION

Ensure to connect the piping among the units in the same refrigerant cycle.

5.1 Piping Materials

- (1) Prepare copper pipes to be supplied in the locality.
- (2) Select the piping size from the Technical Catalog.
- (3) Select clean copper pipes. Make sure there is no dust and moisture inside the pipes. Purge pipes with nitrogen or dry air to remove any dust or foreign matters before connecting pipes. Do not use any tools which produce a lot of swarf such as a saw or a grinder.

•Cautions for Refrigerant Pipe Ends

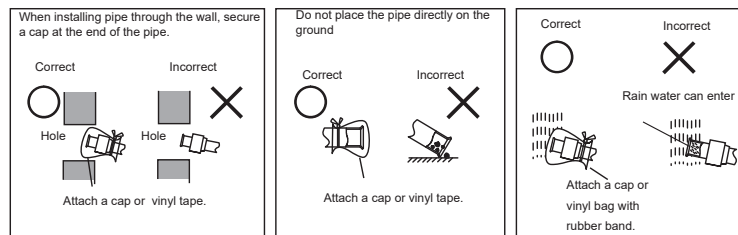

•Cautions for Piping Connection Work

- (1) Connect the indoor/outdoor units with refrigerant pipes. Fix the pipes and pay attention not to contact with weak materials such as ceiling. Otherwise, vibration of piping may give off abnormal sound.
- (2) Apply refrigerant oil slightly on the sheet surface of the pipe and flare nut before the flaring work. Then tighten the flare nut by two spanners with the specified tightening torque. Perform the flaring work on the liquid piping then on the gas piping. Check the gas leakage after the flaring work.

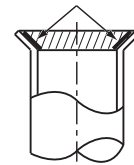

NOTE:

Refrigerant oil is field-supplied.

【Model: FVC68D】

- (3) In case the temperature and humidity inside the ceiling exceed 80.5°F/RH80%, apply additional insulation (approx. 3/8in. thickness) to the accessory insulation. It prevents dew condensation on the surface of the insulation (refrigerant pipe only).
- (4) Perform the air-tight test (601psi for the test pressure).
- (5) Perform cold insulation work by insulating and taping the flare connection and reducer connection. Also insulate all the refrigerant pipes.

- When tightening the flare nut, use two spanners.

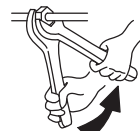

with two spanners

WARNING

Do not apply excessive force to the flare nut when tightening. Otherwise, the flare nut may crack due to aged deterioration and refrigerant leakage may occur. Use the specified tightening torque.

- Piping Thickness and Material
Use the pipe as below.

unit:in.(mm)

Diameter	R410A	
	Thickness	Material
Φ1/4(6.35)	1/32(0.8)	O material
Φ3/8(9.53)	1/32(0.8)	O material
Φ1/2(12.7)	1/32(0.8)	O material
Φ5/8(15.88)	3/64(1.0)	O material
Φ3/4(19.05)	3/64(1.0)	1/2H material
Φ7/8(22.2)	3/64(1.0)	1/2H material
Φ1(25.4)	3/64(1.0)	1/2H material
Φ1-1/8(28.6)	3/64(1.0)	1/2H material
Φ1-1/4(31.75)	3/64(1.1)	1/2H material
Φ1-1/2(38.1)	3/64(1.35)	1/2H material
Φ1-5/8(41.3)	1/16(1.45)	1/2H material
Φ1-3/4(44.5)	1/16(1.55)	1/2H material
Φ2(50.8)	5/64(2.0)	1/2H material
Φ2-1/8(53.98)	5/64(2.0)	1/2H material

5.2 Flaring and Joint

- Flaring Dimension

Perform the flaring work as shown below.

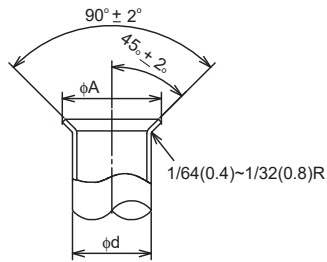

unit:in.(mm)

Diameter (Φd)	A 1/64 +0
	R410A
1/4(6.35)	23/64(9.1)
3/8(9.53)	33/64(13.2)
1/2(12.7)	21/32(16.6)
5/8(15.88)	25/32(19.7)
3/4(19.05)	(*)

(*)It is impossible to perform flaring work with 1/2H material. In this case, use an accessory pipe (with a flare)

- Joint Selection

If you use 1/2H material, you can not perform flaring work. In this case, use a joint selected from the chart below.

<Minimum Thickness of Joint (in.(mm))>

Diameter	R410A
Φ1/4(6.35)	1/64(0.5)
Φ3/8(9.53)	1/32(0.6)
Φ1/2(12.7)	1/32(0.7)
Φ5/8(15.88)	1/32(0.8)
Φ3/4(19.05)	1/32(0.8)
Φ7/8(22.2)	1/32(0.9)
Φ1(25.4)	1/32(0.95)
Φ1-1/8(28.6)	3/64(1.0)
Φ1-1/4(31.75)	3/64(1.1)
Φ1-1/2(38.1)	3/64(1.35)
Φ1-5/8(41.3)	1/16(1.45)
Φ1-3/4(44.5)	1/16(1.55)
Φ2(50.8)	5/64(2.0)
Φ2-1/8(53.98)	5/64(2.0)

< Flare Nut Dimension B (in.(mm))>

Diameter	R410A
Φ1/4(6.35)	43/64(17)
Φ3/8(9.53)	55/64(22)
Φ1/2(12.7)	1-1/32(26)
Φ5/8(15.88)	1-9/64(29)
Φ3/4(19.05)	1-27/64(36)

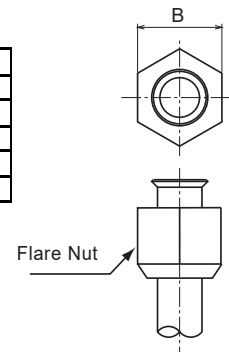

5.3 Caution about Outdoor Unit Installation

Outdoor Unit Alignment

Taking three-module combination of outdoor unit as an example.

Align the outdoor unit from large capacity as $A > B > C$, and outdoor Unit "A" should be located at the indoor unit side.

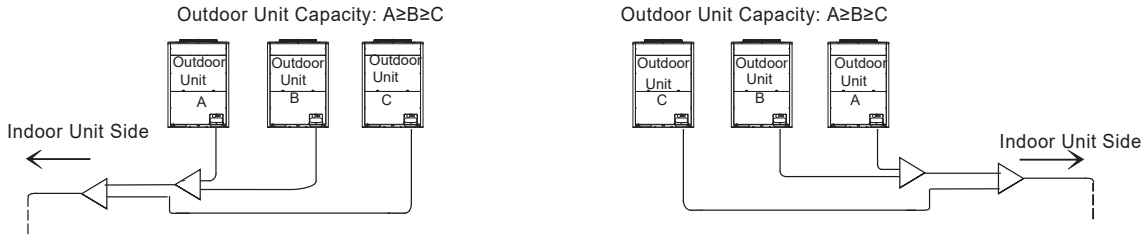

Piping Work between Outdoor Units

(1) Piping Length between Manifold Pipe (at outdoor unit side) and outdoor unit should be $L_A < L_B < L_C < 32.8\text{ft.}(10\text{m})$.

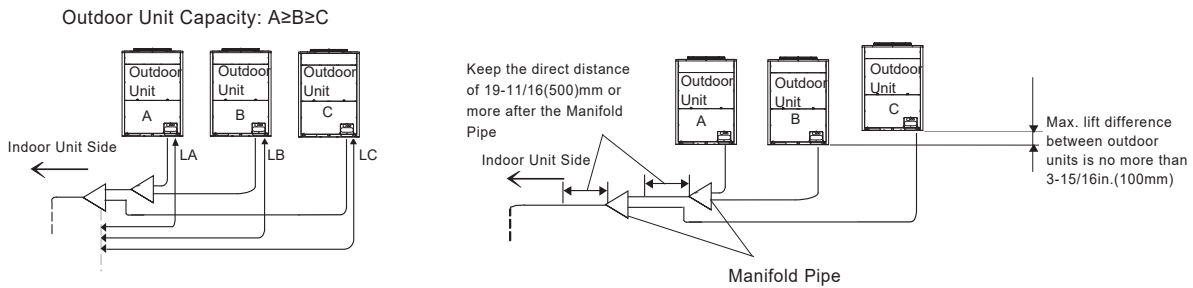

(2) Taking three-module combination of outdoor unit as an example.

Place the Manifold Pipe lower than the outdoor unit piping connection.

In case that the Manifold Pipe is placed higher than the outdoor unit piping connection, keep a distance of 11-13/16in.(300mm)(max.) between the Manifold Pipe and the bottom of the outdoor unit. Also, provide the oil trap (Min.7-7/8in.(200mm)) between the Manifold Pipe and the bottom of the outdoor unit.

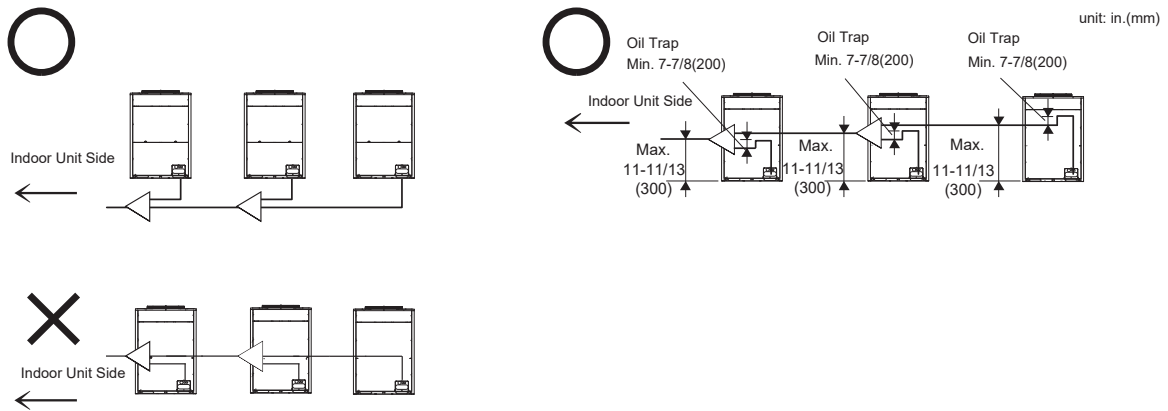

(3) In case the piping length between the outdoor is 6.6ft.(2m) or more, the oil trap should be provided for the gas pipe so that the accumulation of the refrigerant may not occur.

* Less than 6.6ft.(2m)

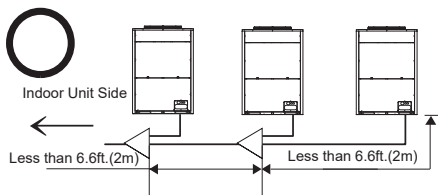

* 6.6ft.(2m) or longer

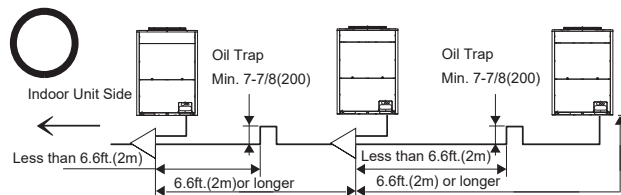

- (4) Place the outdoor unit pipe horizontally or with down gradient toward indoor unit side, or refrigerant oil may accumulate in the pipe.

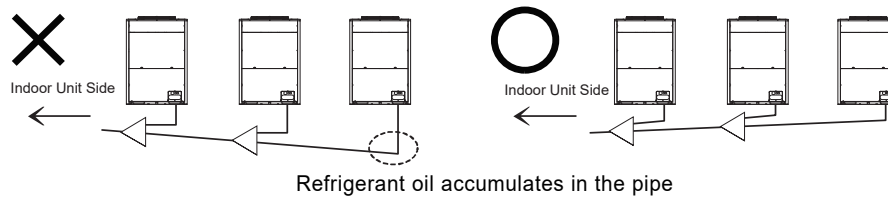

- (5) For servicing, in case that the pipe is placed frontward of the outdoor unit, secure Min. 19-11/16in.(500mm) between the outdoor unit and the Manifold Pipe. When the compressor is replaced, a space of Min. 19-11/16in.(500mm) is required.

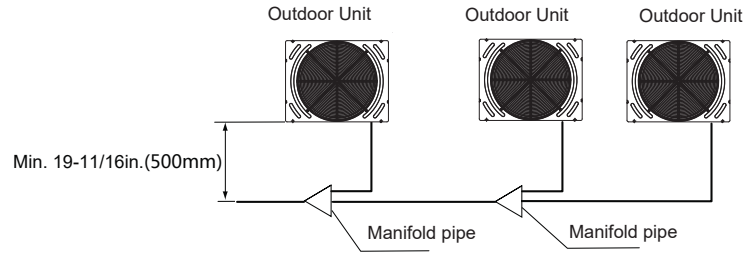

- (6) Direction of Manifold Pipe

Place the Manifold Pipe horizontally toward the ground (within $\pm 15^\circ$) as shown in the figure.

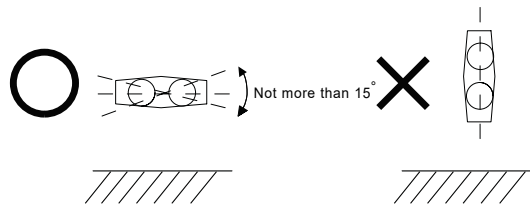

5.4 Piping Connection

Perform piping connection for each outdoor unit.

NOTE:

Ensure that the refrigerant pipes are connected to a unit in the same refrigerant cycle.

- Prepare the refrigerant pipe in the field for the piping work.
- Piping Direction
Fix the pipes adequately in order to avoid vibration and excessive force to the valve

(1) The pipes are available to connect in three directions from the bottom base.

Front side: gash the piping cover 1 with a boxcutter and connect directly through the service lid at the front unit

Bottom side: connect directly from the piping cover 2 on the bottom base

Rear side: connect from the piping cover 2 on the bottom base, then pass through the bottom base to open a hole and connect.

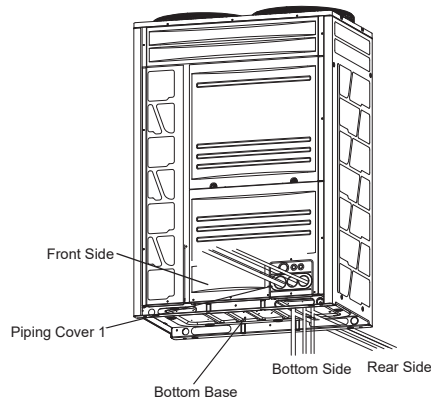

(2) Operation of the stop valve should be performed according to Item 5.4.1.

(3) If the piping is connected from the front side, completely seal the connecting piping with insulation pipe in order to prevent the ingress of water or snow into the conduit.

(4) If the piping is connected from the bottom or rear side, completely seal the pipe passing through the bottom of outdoor unit with insulation conduit in order to prevent ingress of water or snow into the conduit.

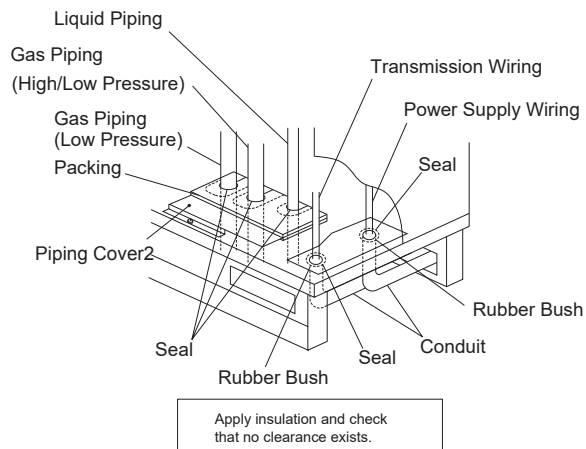

5.4.1 Stop Valve

<Gas Valve>

- (1) Make sure that all the stop valves are closed completely;
- (2) Connect the charging hose to the service port and release gas from the gas pipe;
- (3) Cut off the end of the closing pipe ($\Phi 1/4$ in.) and check that no gas exists inside the gas pipe;
- (4) Remove the stop valve cover;
- (5) Remove the closing pipe from the brazing portion by using a burner. Pay attention to the flame from the burner not to burn the stop valve body.

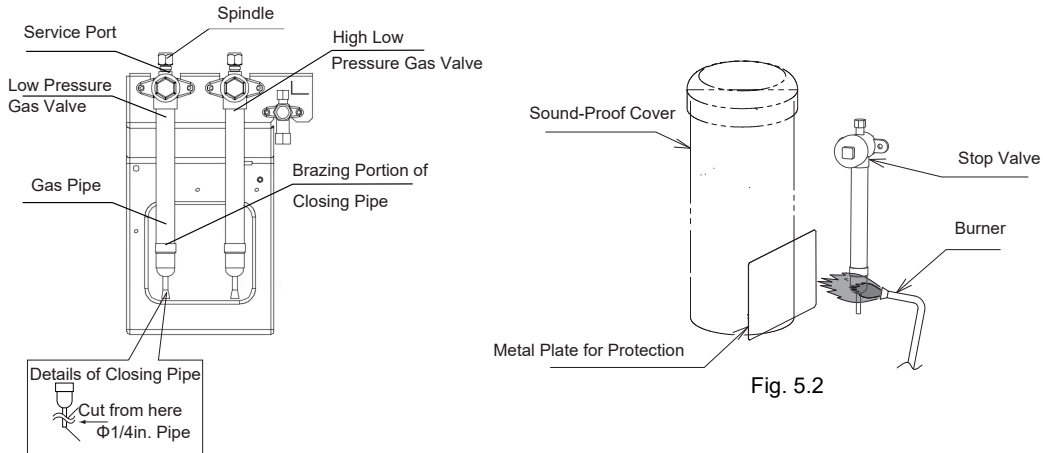
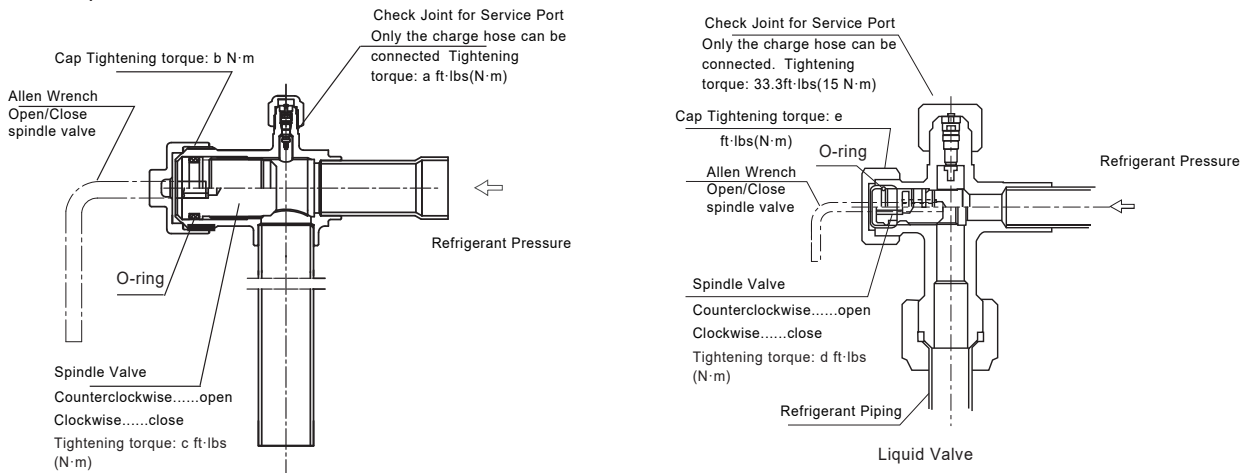

Fig. 5.2

⚠ CAUTION

- Ensure that there is no gas inside the pipe when removing the closing pipe. Otherwise, the pipe may be blown out and it may lead to injuries.
- Protect the return oil pipe and sound-proof cover of the compressor with the metal plate when using a burner.
- Stop valve is detailed as below:



Gas Valve			
Model	Torque a ft·lbs(N·m)	Torque b ft·lbs(N·m)	Torque c ft·lbs(N·m)
72~192	11.1(15)	40.5(55)	22.1(30)

Liquid Valve		
Model	Torque d ft·lbs(N·m)	Torque e ft·lbs(N·m)
72~96	5.2(7)	18.4(25)
120	7.4(10)	22.1(30)
144~192	9.6(13)	25.8(35)

⚠ CAUTION

- Do not apply an excessively big force to the spindle valve at the end of opening, otherwise the stop valve will be damaged.
- At the test run, fully open the spindle. If not, the devices will be damaged.

5.4.2 Piping Connection

- (1) Make sure that the stop valves are closed completely.
- (2) Protect the compressor and sound-proof cover with metal plate when brazing the gas pipe as shown in Fig. 5.2. Pay attention to the flame from the burner not to burn the stop valve body.
- (3) Connect the indoor unit and the outdoor unit with refrigerant piping. Prevent the refrigerant piping from touching weak parts of the building such as wall, ceiling, etc. Abnormal sound may give off due to vibration of the piping.
- (4) As for the flaring work of the field pipe, use the specified tightening torque in Table 5.3. Purge nitrogen gas into the pipe when brazing.
- (5) Insulate the gas pipe and liquid pipe completely.
- (6) Mount the piping cover equipped with the outdoor unit after the piping connection. If not, the unit may be damaged due to the ingress of snow or rain water.

Table 5.3 Flare Nut Tightening Work
Required Tightening Torque

Pipe Size	Tightening Torque (ft·lbs(N·m))
Φ6.35 (1/4)	10~13(14~18)
Φ9.53 (3/8)	25~31(34~42)
Φ12.7 (1/2)	50~62(68~84)
Φ15.88 (5/8)	63~77(85~104)
Φ19.05 (3/4)	90~110(122~149)

NOTES:

1. Ensure that the closing pipe of the gas stop valve(1 place) is removed firstly.
2. Refer to the item 5.2 for flaring work.

Construction Example

< Heat Pump System >

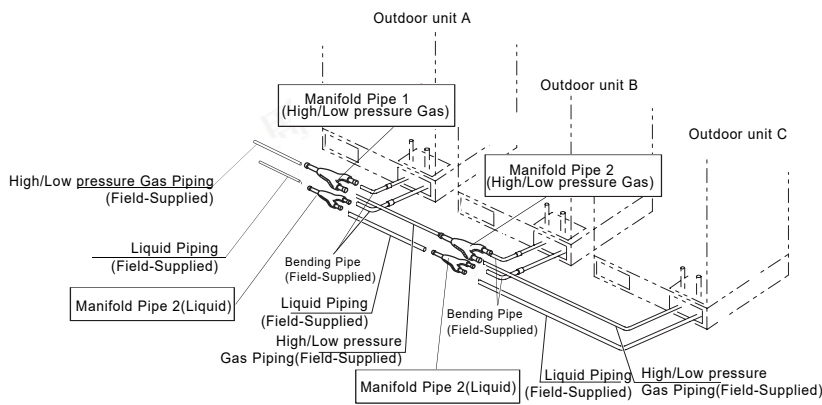

<View-P>

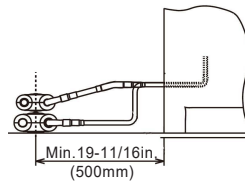

NOTE:

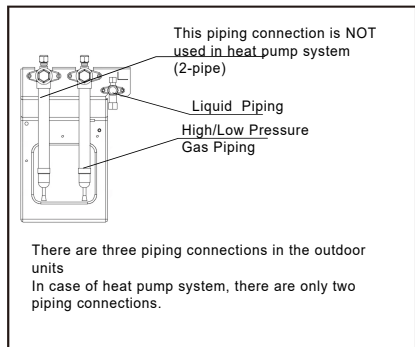

< Front Side Piping Connection >

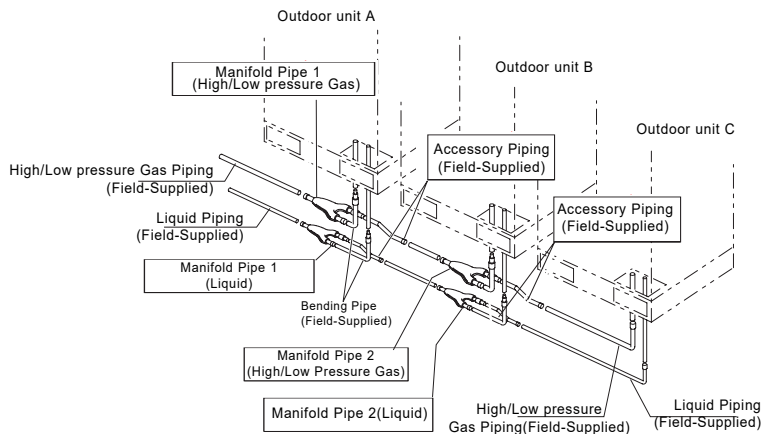

< Downward Piping Connection >

< Heat Recovery System >

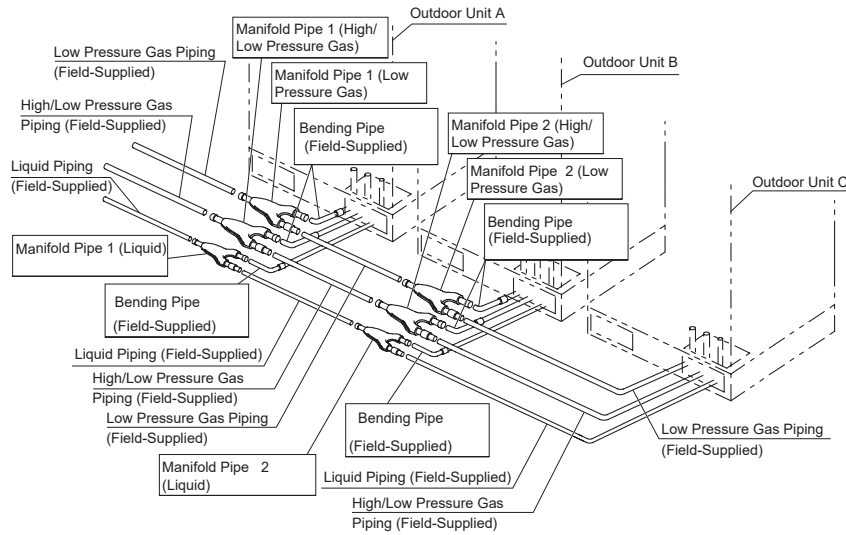

<View-P>

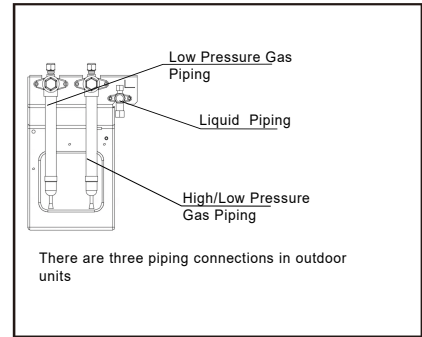
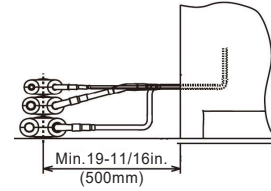

< Front Side Piping Connection >

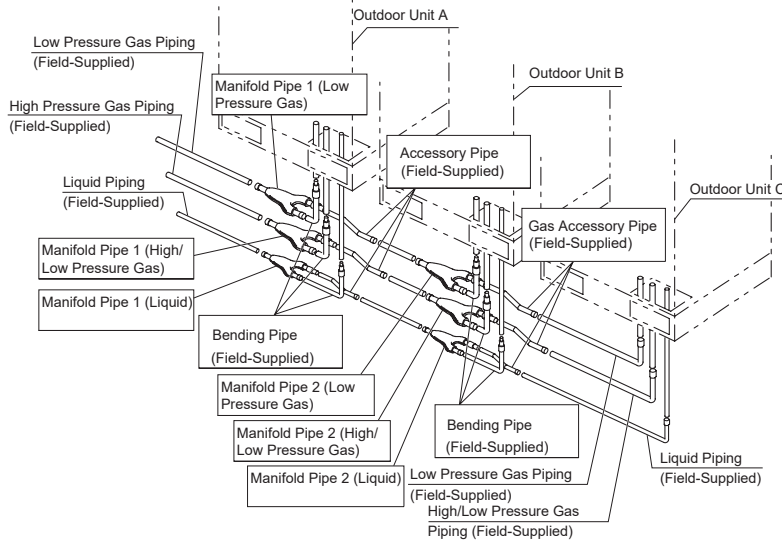

< Downward Piping Connection >

NOTE:

The figure shows the case that the refrigerant pipes are pulled out from the front side piping cover. They can be also pulled out from the bottom base hole.

Piping Size For Outdoor Unit

unit:in.(mm)

Model (kBtu/h)		72	96	120	144	168	192	
Piping Size (φmm)	a	Low Pressure Gas	3/4(19.05)	7/8(22.2)	1(25.4)	1(25.4)	1-1/8(28.6)	1-1/8(28.6)
		High/Low Pressure Gas	5/8(15.88)	3/4(19.05)	7/8(22.2)	7/8(22.2)	7/8(22.2)	7/8(22.2)
		Liquid	3/8(9.53)	3/8(9.53)	1/2(12.7)	1/2(12.7)	1/2(12.7)	5/8(15.88)

NOTE:

If you need to change the piping size for connection, please use the accessory pipe.

6. Electrical Wiring



- Turn OFF the main power switch to the indoor unit and the outdoor unit and wait for more than 10 minutes before electrical wiring or a periodical check is performed.
- Check to ensure that the indoor fan and the outdoor fan have stopped before electrical wiring work or a periodical check is performed.
- Protect the wires, electrical parts, etc. from rats or other small animals. If not, rats may gnaw at unprotected parts, which may lead to a fire.
- Avoid the wirings from touching the refrigerant pipes, plate edges and electrical parts inside the unit. If not, the wires will be damaged and at the worst, a fire will break out.
- Use a medium sensing speed type ELB (Earth Leakage Breaker, activation speed of 0.1 sec. or less). If not, it will cause an electric shock or a fire.
- Fix the cables securely. External forces on the terminals could lead to a fire.
- It is forbidden to use the terminal block of air conditioner power supply to extend power line to other indoor units. Use the power distribution box to extend the power supply wiring on the inner side of the air conditioner. Pay attention to the wiring capacity calculation, otherwise, the wiring capacity is too small and a fire may break out.
- Tighten screws with the following torque.
 - M4: 0.7 to 1.0 ft·lbs(1.0~1.3 N·m)
 - M5: 1.5 to 1.8 ft·lbs(2.0~2.4 N·m)
 - M6: 3.0 to 3.7 ft·lbs(4.0~5.0 N·m)
 - M8: 6.6 to 8.1 ft·lbs(9.0~11.0 N·m)
 - M10: 13.3 to 17 ft·lbs(18.0~23.0 N·m)

6.1 General Check

- (1) Make sure that the field-selected electrical components (main power switches, fuse, wires, conduit connectors and wire terminals) comply with National Electrical Code (NEC).
 - Supply electrical power to each outdoor unit. An ELB, fuse and main switch should be used for each outdoor unit. Otherwise, it may lead to an electric shock, or a fire may break out
 - The power supply for the indoor unit and outdoor unit should be provided separately. Connect a power supply wiring to each indoor unit to be connected to the same outdoor unit.
- (2) Check to ensure that the power supply voltage is within $\pm 10\%$ of the rated voltage.
If the power supply voltage is excessively low, the system does not start due to the voltage drop.
- (3) Check the size of the electrical wires.
- (4) The air conditioner may not operate properly under the following.
 - In case that the air conditioner has to share power transformer with device of high electricity consumption*
 - In case that the power source wires for the device* and the air conditioner are adjacent to each other.* lift, container crane, rectifier for electric railway, inverter power device, arc furnace, electric furnace, large-sized induction motor and large-sized switch.
For the cases mentioned above, induction surge of the power supply wiring for the air conditioner may occur due to a rapid change in electricity consumption of the device and an activation of switch. Therefore check the local regulations and standards before performing electrical work in order to protect the power supply wiring of the air conditioner.
- (5) Check to ensure that the earth wire of the outdoor unit is connected.

6.2 Electrical Wiring Connection



The ELB (earth leakage breaker), FUSE and S (main switch) must be installed to the each power source of outdoor unit. If not, it may cause an electrical shock or a fire.

Perform the electrical work according to the regulations of each region and this manual

NOTE: Supply the power source of outdoor units and indoor units respectively.

(1) Power Supply Wiring

Supply the power sources to the each outdoor unit respectively. Power source wiring is fundamentally according to this method.

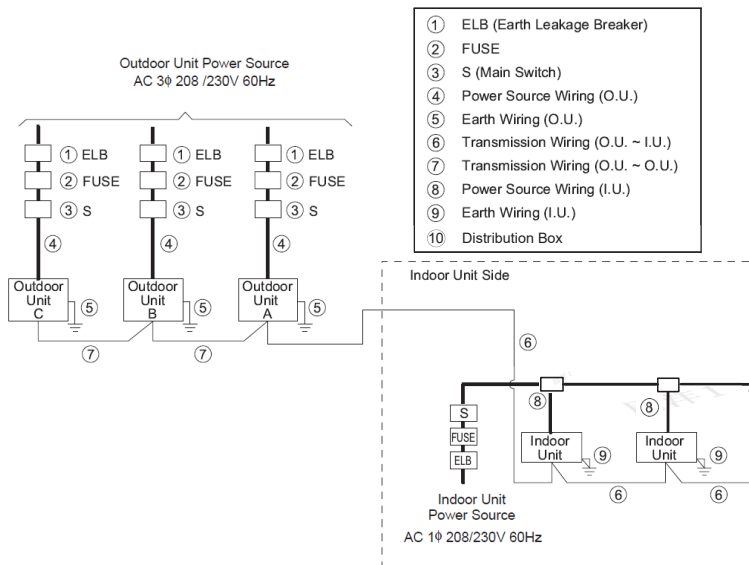

(2) Electrical Characteristics

Note the following when selecting wiring:

- Use the charts below to select appropriate sized breakers / fuses / overcurrent protection switches and wiring in accordance with local codes.
- Ensure communication cable is a minimum of AWG18 (0.82mm²), 2-Conductor, Stranded Copper.

Table 6.1 Minimum Wire Sizes for Power Source on Field

Model	Outdoor Unit							Inverter 1	Inverter 2	Fan Motor
	Hz (Hz)	Voltage (V)	Max. (V)	Min. (V)	MCA (A)	MOP (A)	Max. Fuse (A)			
CHV6-072URB	60	208/230	253	188	34.3	45	45	25.2	-	2.8
CHV6-096URB	60	208/230	253	188	41.2	50	50	30.7	-	2.8
CHV6-120URB	60	208/230	253	188	49.3	60	60	37	-	1.5×2
CHV6-144URB	60	208/230	253	188	60.1	80	80	24.2	24.2	2.8×2
CHV6-168URB	60	208/230	253	188	62.3	80	80	25.2	25.2	2.8×2
CHV6-192URB	60	208/230	253	188	78.1	100	100	32.2	32.2	2.8×2

Model	Wiring Size		
	Power Supply Wiring (AWG)	Ground Wiring (AWG)	Communication Cable (AWG)
CHV6-072URB	8	8	18
CHV6-096URB	8	8	18
CHV6-120URB	6	6	18
CHV6-144URB	4	4	18
CHV6-168URB	4	4	18
CHV6-192URB	2	2	18

MCA: Minimum Circuit Ampacity (A)
MOP: Maximum Overcurrent Protective Device (A)
MOC: Maximum Operating Current (A)
FLA: Fan Motor Running Ampacity (A)

⚠ CAUTION

Install a multi-pole main switch with a space of 1/8in.(3mm) or more between each phase.

NOTES:

- 1) When the power supply wiring is longer, select the minimum wiring size of which the voltage drop is within 2%.
- 2) Power supply voltage should be satisfied with the followings:
 supply voltage: rated voltage within +10%
 starting voltage: rated voltage within -15%
 operating voltage: rated voltage within $\pm 10\%$
 imbalance between phases: within 3%
- 3) Do not connect the earth wire to the gas pipe, water pipe, lightning conductor.
 Gas pipe: an explosion and ignition may occur when gas leaks.
 Water pipe: there is no effect of earth wire when a hard vinyl pipe is used.
 Lightning conductor: the earth electric potential abnormally increases when a lightning conductor is used.

6.3 Electrical Wiring Connection

Connect the electrical wirings according to the following figure.

- (1) Fix the cord band base onto the mounting plate with the short screw, the cord band base and short screw are in the fastener pouch
- (2) Wrap power wiring once around the big magnet ring in electrical accessory pouch, lead power wiring and earth wiring through the hole on the mounting plate and mount the cord band with the long screw to secure power wiring and earth wiring; then connect power lines to Terminal on TB1, and earth wire connect to the terminal in the electrical control box.
- (3) Wrap transmission wiring between indoor and outdoor units twice around the small magnet ring in electrical accessory pouch, then connect it to Terminal 1 and 2 of TB2 on PCB1. As for transmission wiring between outdoor units of the same refrigerant system, please connect to Terminal 3 and 4 of TB2 on PCB1.
- (4) Tighten screws on the terminal board, and secure power wiring and transmission wiring with cord clamp.

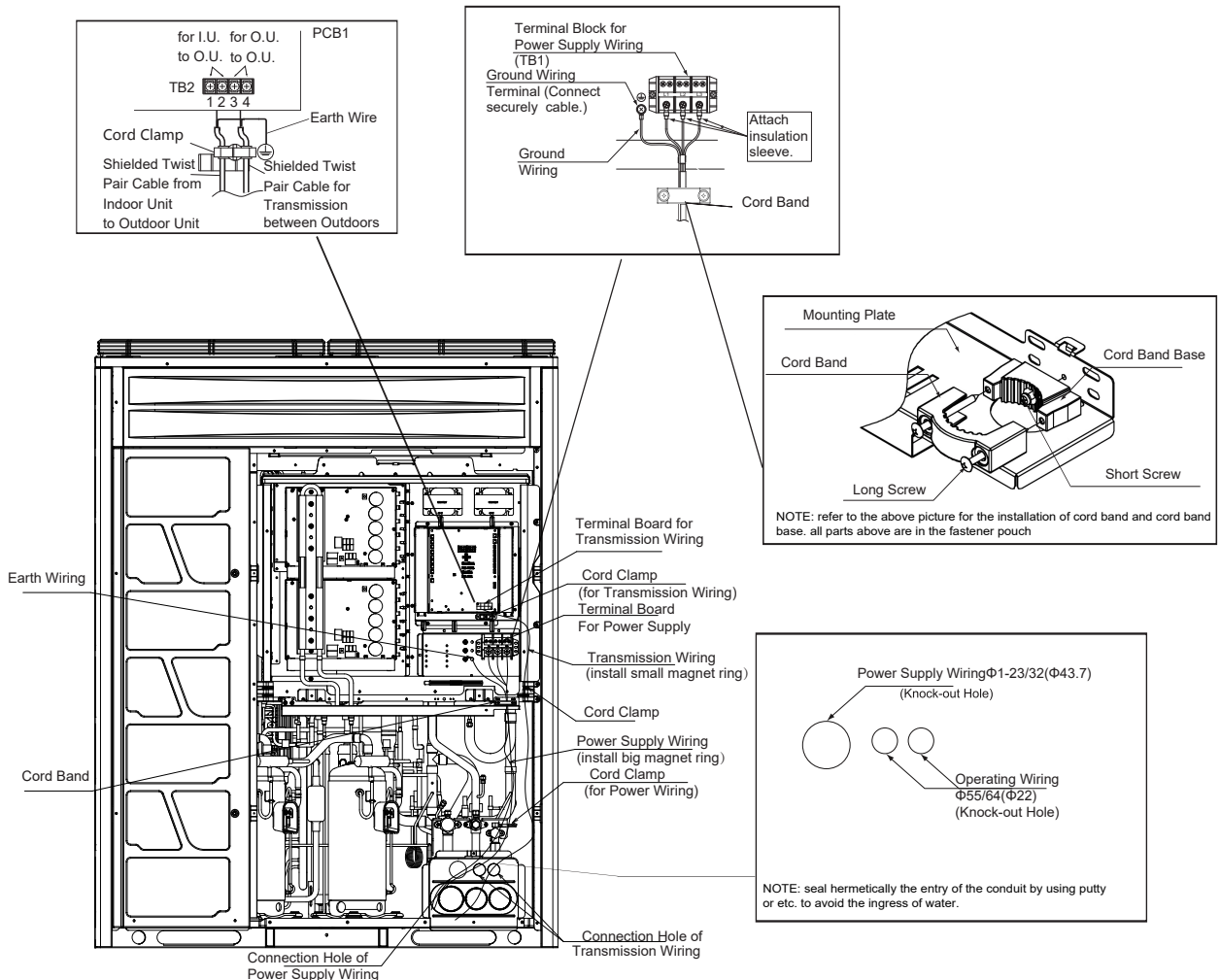

<Tighten screws for the terminal board according to the following table.>

Screw Size	Tightening Torque
M4	0.7~1.0 ft·lbs(1.0~1.3N·m)
M5	1.5~1.8 ft·lbs(2.0~2.4N·m)
M6	3.0~3.7 ft·lbs(4.0~5.0N·m)
M8	6.6~8.1 ft·lbs(9.0~11.0N·m)
M10	13.3~17 ft·lbs(18.0~23.0N·m)



CAUTION

Pay attention to the followings to run through the cables under the unit using conduit tube. (The guard plater is required to remove before performing piping and wiring works.)

NOTES:

1. Do not lead the power supply wiring and transmission wiring through the same conduit. Moreover, keep a distance of at least 1-31/32(50mm) between the power supply wiring and transmission wiring
2. Cut cross line at rubber bush and securely attach it to the knock-out hole for cable protection.
3. Attach the guard plate to avoid entrance of rats or other small animals into the unit.
4. Avoid the wirings from touching the refrigerant pipes, plate edges and electrical parts inside the unit.
5. Completely seal the end of conduit tube with sealing materials to avoid the ingress of rain into the conduit. Make a drain hole at the lowest part of the conduit tube.



CAUTION

Tightly secure the power source wiring by using the cord clamp inside the unit.

6.4 Electrical Wiring Connection of The System

- (1) Connect power supply wiring to each outdoor unit. Connect an ELB, fuse and main switch (es) to each outdoor unit.
- (2) Connect power supply wiring to each indoor unit to be connected to the same outdoor unit. Connect an ELB, fuse and main switch(es) to each indoor unit group.
- (3) Connect the transmission wiring between indoor units and outdoor units, as shown in figure.
- (4) Connect the transmission wiring in the same refrigerant cycle. (In case that the refrigerant pipe of indoor unit is connected to the outdoor unit, connect the transmission wiring to the same indoor unit.) Connecting the refrigerant pipe and transmission wiring to the systems of different refrigerant cycle may lead to malfunction.
- (5) Use 2-core lead wires such as shielded twist pair cable for the transmission wiring. (Do not use 3-core or over.)
- (6) Use the same kind of cables for the H-NET system of the same refrigerant cycle.
- (7) The transmission wiring is required to be separated from the power supply wiring. Keep a distance of at least 1-31/32in.(50mm) between the transmission wiring and the power supply wiring, and also a distance of min. 49.2ft.(5m) between the transmission wiring and power supply wiring of other electrical device. If the above is not secured, put the power supply wiring into the metal conduit to separate from other wirings.
- (8) Connect the following transmission wiring to Terminal 1 and 2 of TB2 in the outdoor unit A (main unit).
 - between outdoor unit and indoor unit
 - between outdoor unit and indoor unit in other refrigerants cycles
- (9) Do not connect the power supply wiring to terminal board for transmission wiring (TB2). Printed circuit board may be damaged.
- (10) Connect the earth wire for outdoor/indoor units. The earth wiring work under the condition of 100 Ω (max.) ground resistance should be performed by a qualified person.

NOTES:

1. For the combination modules, DSW settings of Main and Sub are required.
2. Alarm occurs if the transmission wires between outdoor units are connected to Terminal 1 and 2 for H-NET.
3. In case that alarm is indicated on the LCD of Main outdoor unit, follow the "7-segment" display when the main outdoor unit checking.
4. Perform function setting from Main outdoor unit.

When indoor units are connected to the SW BOX, refer to technical handbook for wiring.

< Heat Pump System & Heat Recovery System Without Switch Box >

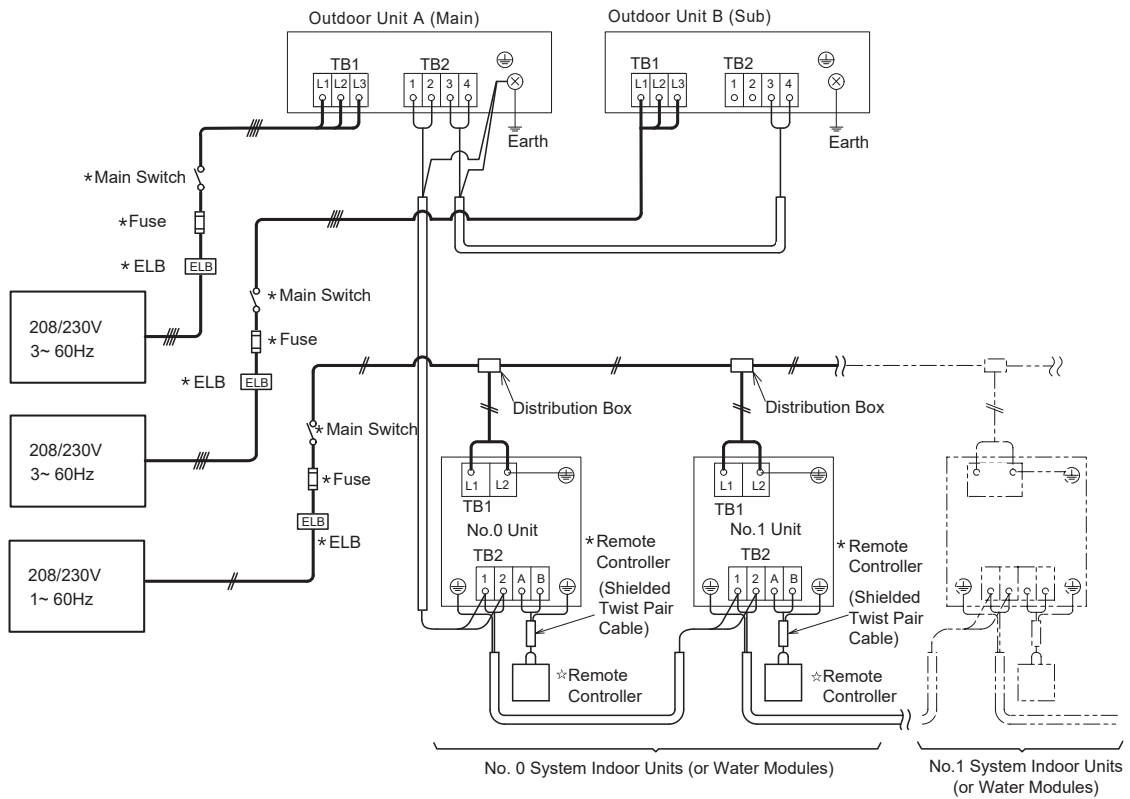

< Heat Recovery System with Switch Box >

For Single Branch SW BOX

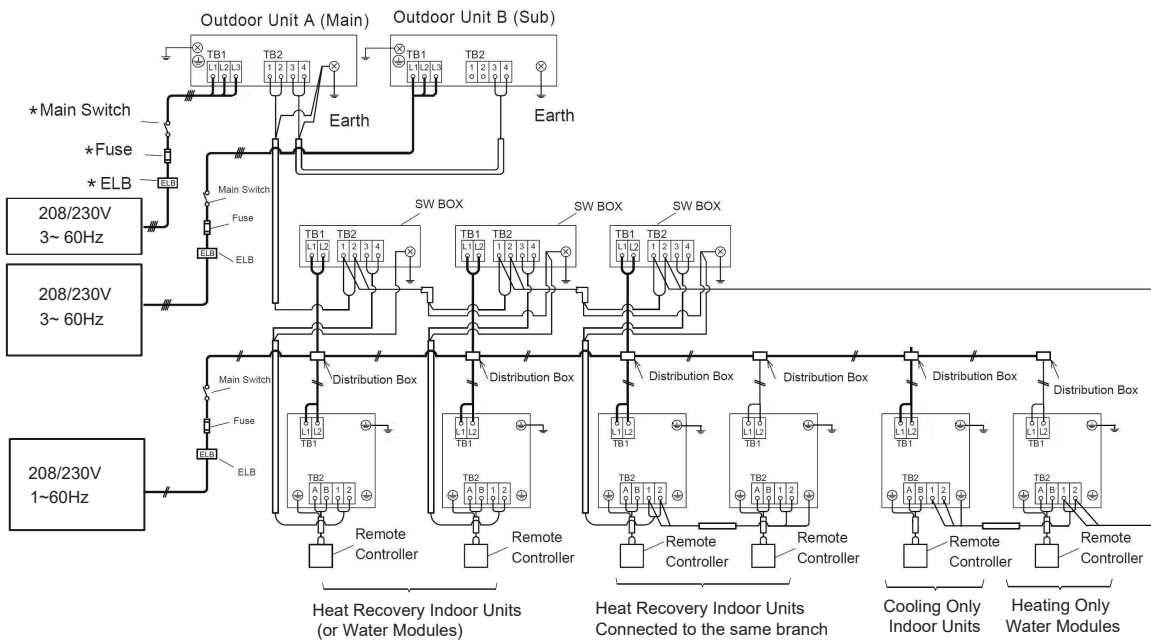

For Multi Branch SW BOX

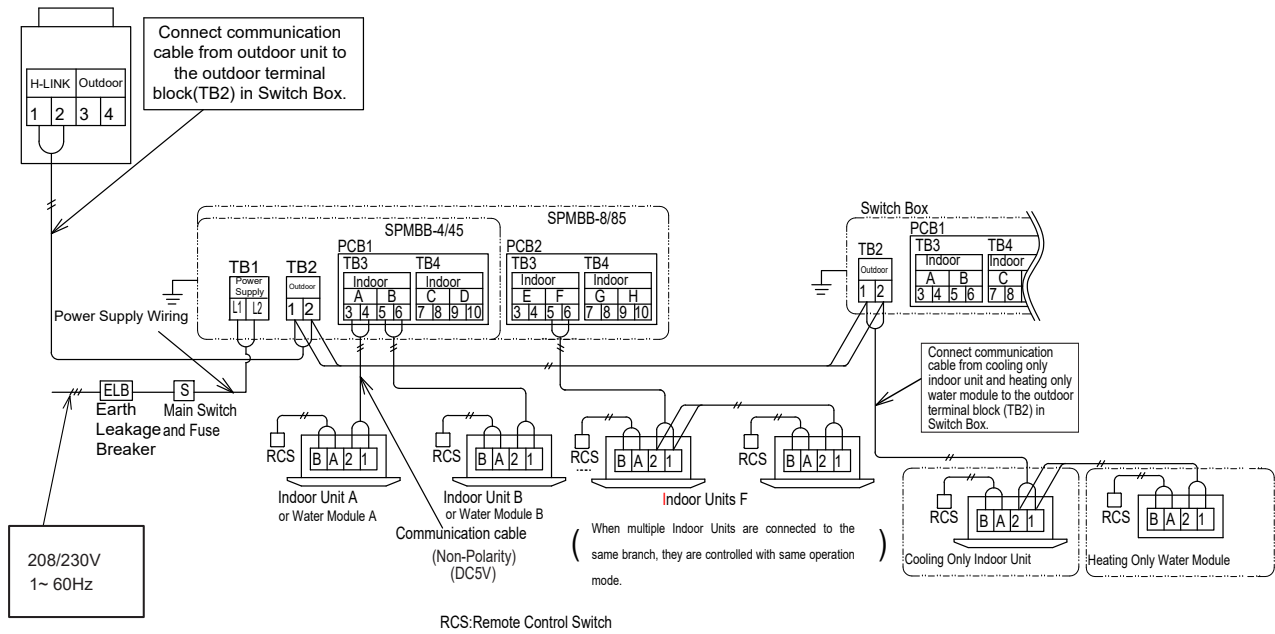

(a) SPMBB-4/45/SPMBB-8/85

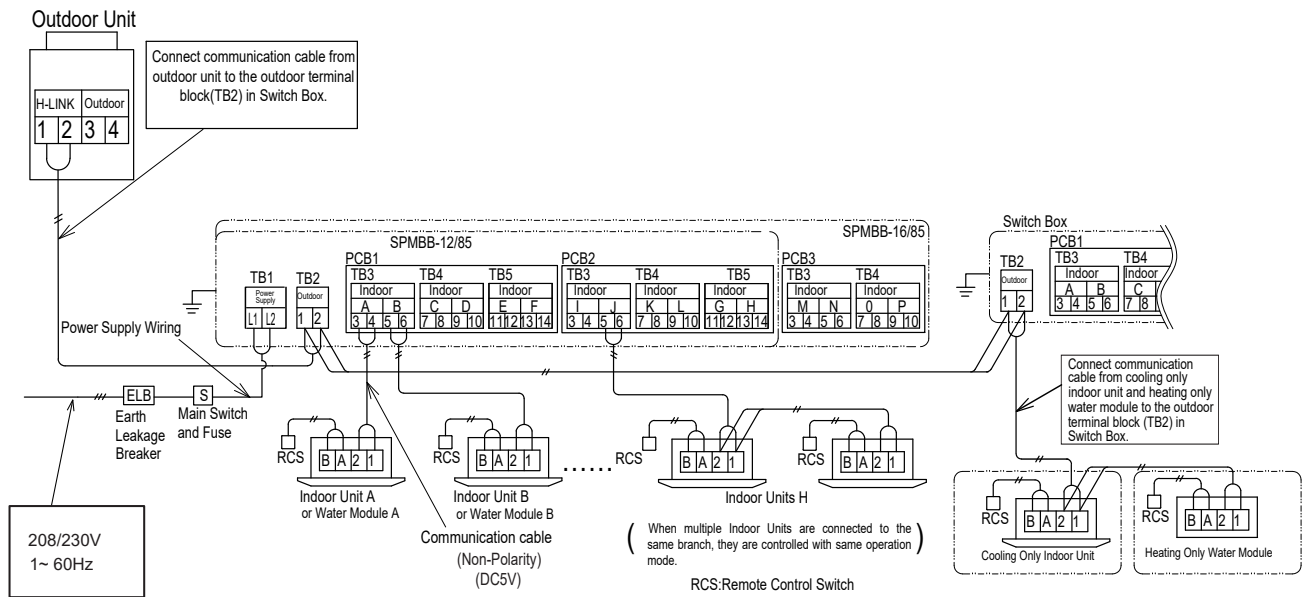

(b) SPMBB-12/85/SPMBB-16/85

NOTES:

- When multiple indoor units are connected to the same single SW BOX, they are controlled with the same operation mode.
- When multiple indoor units are connected to the same branch of the multi SW BOX, they are controlled with the same operation mode.
- Do not apply excessive voltage to the communication cable DC5V (non-polarity) between the outdoor unit and the SW BOX, between the SW BOX and the indoor unit or between SW BOXES.
- Use 2-conductor (at the most) shielded communication cable.
- Connect the communication cable for the outdoor unit to terminals “1” and “2” on TB2 in the SW BOX.
- Connect the communication cable for the cooling only indoor unit or heating only water module to the terminal “1” and “2” on TB2 in the SW BOX.
- For a SW BOX in the same refrigerant cycle, an electrical power supply can be supplied by one main switch.
- Do not connect the power supply wiring to the terminal block for transmission cable.
- Connect the ground wiring for the outdoor/indoor units and SW BOX. When ground resistance is less than 100 Ω, ground wiring work should be performed by the qualified electrician.
- Do not run communication cable along with power supply wirings in the SW BOX. Separate communication cables from the power supply wirings.
- Water module should be connected to an exclusive branch of the SW BOX.

6.5 DIP Switch Setting of Outdoor Unit

TURN OFF all power sources before setting.

Without turning OFF, the switches do not work and the contents of the setting are invalid. However, DSW4-No.1, 2, 4 can work during power source is ON. The mark of “■” indicates the position of dip switches.

NOTE

- By using switch DSW4, the unit starts or stops 10 to 20 seconds after the switch is operated.
- Number this outdoor unit to distinguish from other outdoor units for service and maintenance.
And write the number in the box on the right.
- Do not touch any other electrical parts when operating switches on the PCB.

- **Setting for Transmitting**
It is required to set the outdoor unit Nos., refrigerant cycle Nos. and terminal resistance for this H-NET system.
- **Setting of Outdoor Unit No.**
In case of the combination module, set DSW6 as shown below.

Basic Unit (Before Shipment)	Combination Module		
	Outdoor Unit A (No.0) (Main)	Outdoor Unit B (No.2)	Outdoor Unit C (No.3)
ON OFF <input type="checkbox"/> <input checked="" type="checkbox"/> <input type="checkbox"/> <input type="checkbox"/> 1 2 3 4	ON OFF <input checked="" type="checkbox"/> <input type="checkbox"/> <input type="checkbox"/> <input type="checkbox"/> 1 2 3 4	ON OFF <input type="checkbox"/> <input checked="" type="checkbox"/> <input type="checkbox"/> <input type="checkbox"/> 1 2 3 4	ON OFF <input type="checkbox"/> <input type="checkbox"/> <input checked="" type="checkbox"/> <input type="checkbox"/> 1 2 3 4

- **Setting for British Unit**
Before shipment, No.4 pin of DSW7 is set at “OFF”, metric units can be used;
set the No.4 pin of DSW7 at “ON” to use the British units.

- Setting of Refrigerant Cycle No.

In the same refrigerant cycle, set the refrigerant cycle No. for the outdoor units as shown below.

NOTE: In the same refrigerant cycle, set the same refrigerant cycle No. for the outdoor unit and the indoor unit.

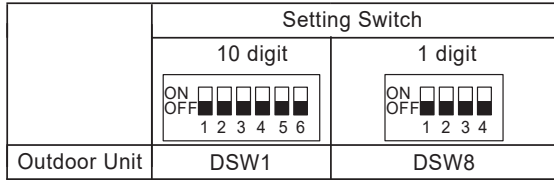

0~9 Binary System Dip Setting Method for DSW8

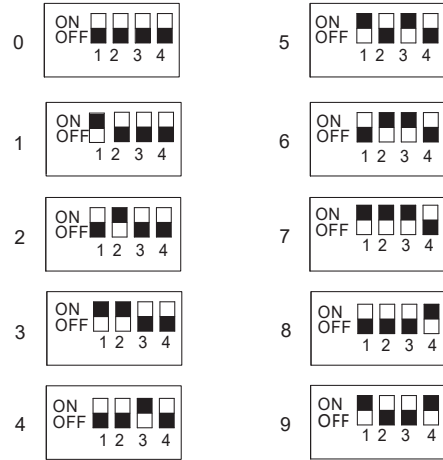

Ex: In Case of Setting Refrigerant Cycle No. 25

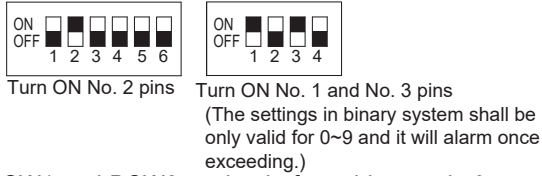

DSW1 and DSW8 setting before shipment is 0.

Maximum in setting refrigerant cycle No. is 63.

- Setting of Terminal Resistance

Before shipment, No.1 pin of DSW10 is set at the "ON" side. In the case that the outdoor units quantity in the same H-NET is 2 or more, set No. 1 pin of DSW10 at the "OFF" side from the 2nd refrigerant group outdoor unit. If only one outdoor unit is used, no setting is required.

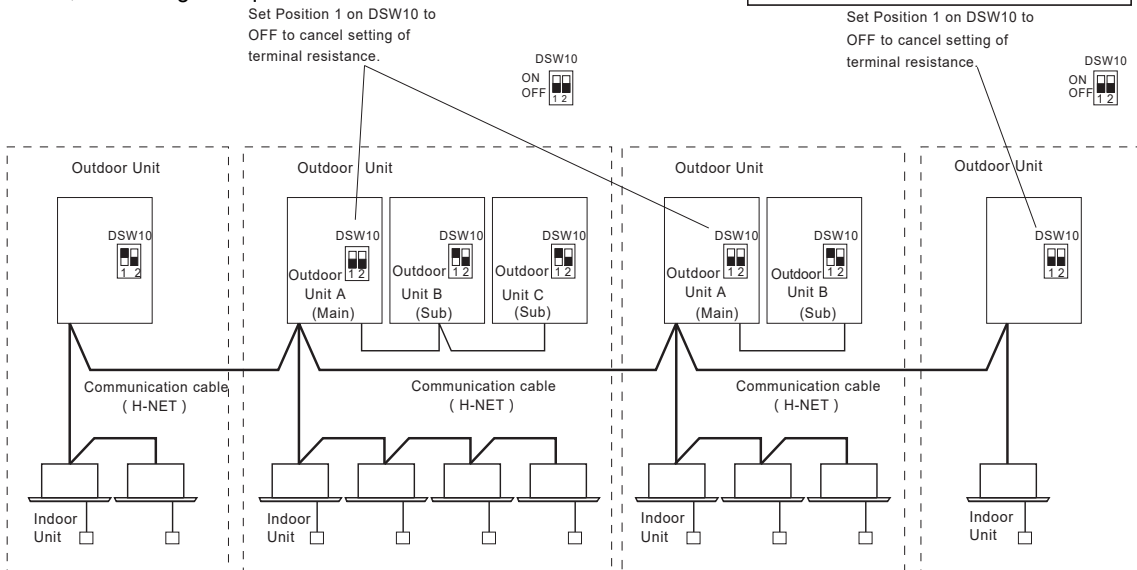
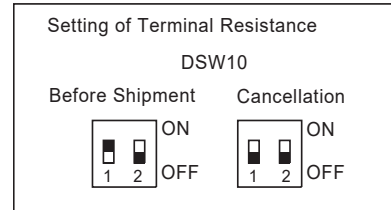

● Function Setting

External Input/Output and Function Setting

Start of Setting

Turn ON DSW4-No.4.
Press PSW1 for at least 3 seconds.
"Menu Mode" will be indicated.

End of Setting

Press PSW1 for at least 3 seconds.
The display indication become to normal indication.
Turn OFF DSW4-No.4.

NOTE:
Release "Menu Mode" after the setting is completed.
Otherwise, the air conditioner may not operate properly.

Menu Mode

Press PSW1 once.

For more details, refer to "Checking of Outdoor Unit by PCB" in the Service Manual.

For the setting mode, refer to ① below.

For the function setting, refer to ② below.

Arrangement of Dip Switch Setting

① [External Input and Output Setting]

By pressing the push-switches PSW3 (▶) and PSW5 (◀), the function No. can be selected.
PSW4 (▼): forward, PSW2 (▲): backward

Fill out the selected function setting No. in the box of the table as shown on the right. 1

Item	SEG2	SEG1	SET
1 Input Setting 1 CN17[1-2 pin]	11	1	<input type="text"/>
2 Input Setting 2 CN17[2-3 pin]	12	2	<input type="text"/>
3 Input Setting 3 CN18[1-2 pin]	13	3	<input type="text"/>
4 Input Setting 1 CN16[1-2 pin]	131	1	<input type="text"/>
5 Input Setting 2 CN16[1-3 pin]	132	2	<input type="text"/>

(Setting before shipment)

Before shipping, the input/output function settings are specified to each input/output terminal according to above table.

Setting External Input/Output Functions

Function No.	Input	Output
1	Fixing Heating Operation Mode	Operation Signal
2	Fixing Cooling Operation Mode	Warning signal
3	Demand Stoppage	Compressor ON Signal
4	Outdoor Fan Motor Start/Stop	Frost Signal
5	Forced Stoppage	-
6	Demand Current Control 40%	-
7	Demand Current Control 60%	-
8	Demand Current Control 70%	-
9	Demand Current Control 80%	-
10	Demand Current Control 100%	-
11	Low Noise Setting 1	-
12	Low Noise Setting 2	-
13	Low Noise Setting 3	-
0	No set	No set

The same input/output function setting can not be set to different input/output terminals.
If set, a setting of larger function number is became invalid.

② [Function Setting]

By pressing the push-switches PSW3 (▶) and PSW5 (◀), the setting can be changed.
PSW4 (▼): forward, PSW2 (▲): backward

Refer to the Technical Catalog for more details. (Example)

Fill out the selected function setting No. in the space of the table as shown. 1

Item	SEG2	SEG1	SET
1 Fan Intermittent Operation during Heating Thermo-OFF	FR	0	<input type="text"/>
2 Night-Shift	n1	0	<input type="text"/>
3 Cancellation of Outdoor Ambient Temperature Limit	OS	0	<input type="text"/>
4 Defrost for Cold Area (Change of Defrost Condition)	Jo	0	<input type="text"/>
5 Slo (Fan Speed) Defrost Setting	bJ	0	<input type="text"/>
6 Cancellation of Hot Start	Hf	0	<input type="text"/>
7 Priority Capacity Mode	nU	0	<input type="text"/>
8 Frequency Control (Control Target Value for Cooling Compressor)	Hc	0	<input type="text"/>
9 Frequency Control (Control Target Value for Heating)	Hh	0	<input type="text"/>
10 Indoor Expansion Valve (Control Target Value for Cooling)	Sc	0	<input type="text"/>
11 Indoor Expansion Valve (Control Target Value for Heating)	Sh	0	<input type="text"/>
12 Indoor Expansion Valve (Opening during Heating Operation Stoppage)	Si	0	<input type="text"/>
13 Indoor Expansion Valve (Opening during Heating Thermo-OFF)	So	0	<input type="text"/>
14 Indoor Expansion Valve (Initial Opening during Heating Thermo-ON)	ci	0	<input type="text"/>
15 Indoor Expansion Valve (Initial Opening for Cooling)	cb	0	<input type="text"/>
16 Outdoor Expansion Valve (Initial Opening for Heating)	ch	0	<input type="text"/>
17 Sound Reduced Function	db	0	<input type="text"/>
18 Demand Function Setting	dE	0	<input type="text"/>
19 Wave Function Setting	UE	0	<input type="text"/>
20 Protection of Decrease in Outlet Temperature for Cooling	Fb	0	<input type="text"/>
21 Reserved	Ff	0	<input type="text"/>
22 Adjustment of Fan Rotation (for multiple installation)	Fo	0	<input type="text"/>
23 Min. Indoor Exp-Valve Opening Setting at Heating Functions SW-OFF	F1	0	<input type="text"/>
24 Snow Model Setting	F4	0	<input type="text"/>
25 Indoor VIP Function	U1-U5	0	<input type="text"/>
26 Automatic Night-Shift	n6	0	<input type="text"/>
27 Height Difference Setting	Hd	0	<input type="text"/>
28 Economic Function Setting	Ec	0	<input type="text"/>
29 Quantity of Water Module Connected	n3	0	<input type="text"/>
30 Type of Water Module	H4	0	<input type="text"/>
31 Performance Balance between Indoor Unit and Water Module	U1	0	<input type="text"/>

Note:
(1) The function setting of "n3" must be set to correct value according to the quantity of water module connected, otherwise, ALARM 37 may be triggered. (For example, in case of the quantity of water module in a system is three, then the value of "n3" should be set to "3".)
(2) The function setting of "H4" must be set to correct value according to the type of water module connected:
H4=0 (default) : water module should be used in a three pipes heat recovery system.
H4=2: water module should be used in a two pipes heat pump system.
(2) The function setting of "U1" can be set according to application requirement:
U1=0 (default) : performance balance between indoor unit and water module.
U1=1: indoor unit has priority on performance.

27

7. Additional Refrigerant Charge

7.1 Air-Tight Test

(1) Check to ensure that the stop valves are closed completely before air-tight test.

<Tightening Check of Stop Valves>

After connecting the pipe, remove the cap of stop valve for liquid.

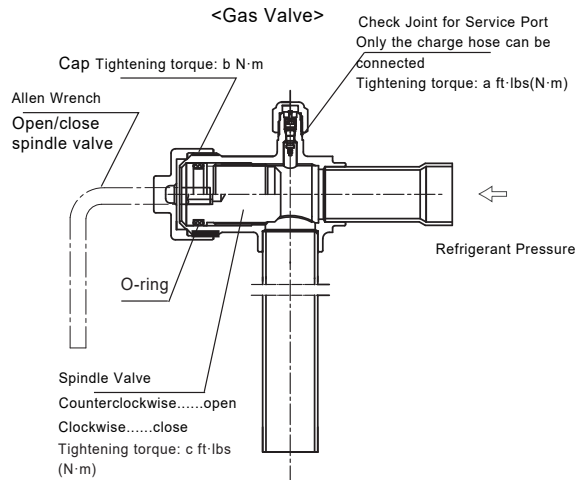

Model	Torque a ft·lbs(N·m)	Torque b ft·lbs(N·m)	Torque c ft·lbs(N·m)
72~192	11.1(15)	40.5(55)	22.1(30)

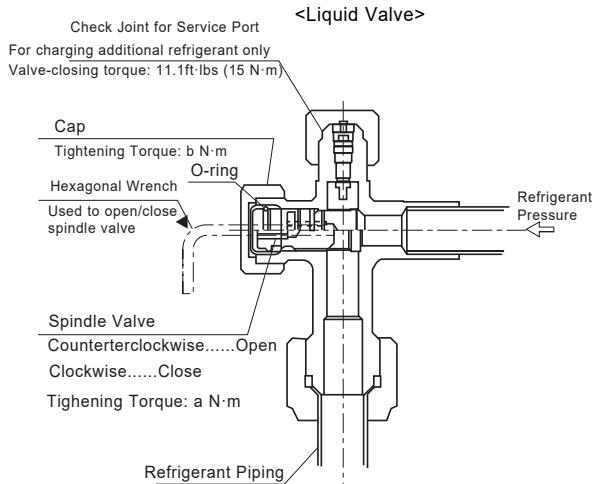

Model	Torque a ft·lbs(N·m)	Torque b ft·lbs(N·m)
72~96	5.2(7)	18.4(25)
120	7.4(10)	22.1(30)
144~192	9.6(13)	25.8(35)

- (2) Connect the indoor units and the outdoor unit with field-supplied refrigerant piping. Suspend the refrigerant piping at specified points and prevent the refrigerant piping from touching weak parts of the building such as wall, ceiling, etc.. Vibration of the piping may give abnormal sound.
- (3) Connect the manifold gauge to a vacuum pump or a nitrogen cylinder and the check joint of the liquid stop valves and gas stop valves with charging hoses.
- (4) Apply nitrogen gas pressure of 601psi(4.15MPa). Do not open the stop valves.

⚠ DANGER

Be sure to use Nitrogen Gas for air-tight test. If other gases such as oxygen gas, acetylene gas or fluorocarbon gas are accidentally used, it may cause explosion or gas intoxication.

- (5) Check for any gas leakage at the flare nut connections, or brazed parts by use of a foaming agent or gas leak detector.
- (6) Mount the piping insulation materials after connecting the pipe.

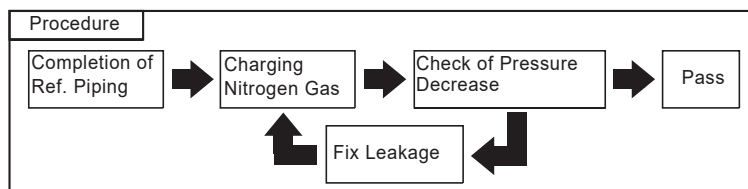

< Heat Pump System >

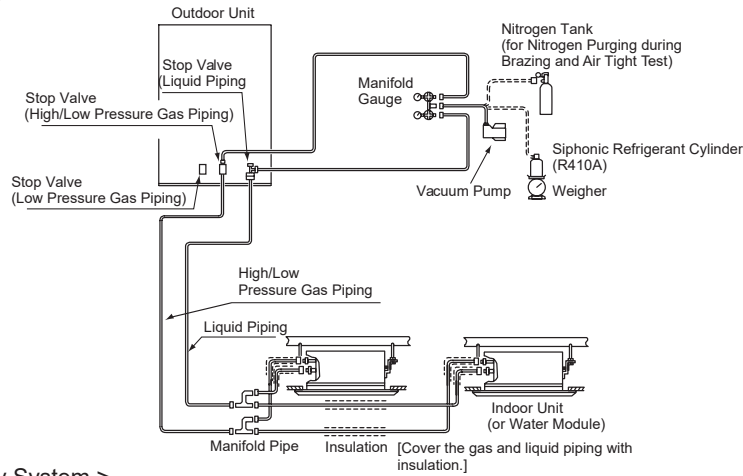

< Heat Recovery System >

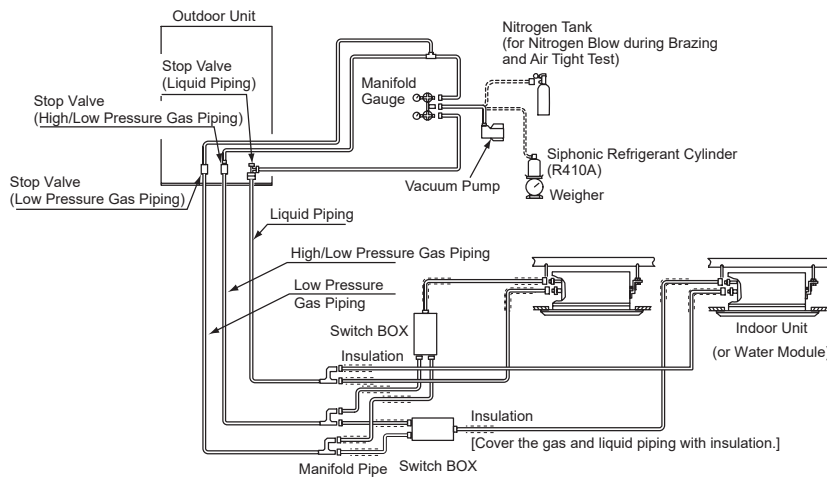

Fig. 7.1 Air-Tight Test

7.2 Vacuuming

- (1) Connect manifold gauge and vacuum pump to the check joints.
- (2) Continue vacuum pumping for one to two hours until the pressure reaches -14.5Psi(-0.1MPa /-756mmHg) or lower.

After vacuum pumping, stop the valve of manifold gauge, stop the vacuum pump and leave it for one hour. Check to ensure that the pressure in the manifold gauge does not increase.

- (3) Tighten the cap of check joint after vacuum pumping.

NOTES:

1. If tools or measuring instruments come into contact with the refrigerant, use the tools or the measuring instruments exclusively for R410A.
2. If vacuum degree of -14.5Psi(-0.1MPa /-756mmHg) is not available, it is considered that there is a gas leakage. Check for any gas leakage once again. If no leakage exists, operate the vacuum pump for one to two hours.



CAUTION

- Insulate the refrigerant pipes as shown in Fig.7.2. After connecting the refrigerant piping, seal the refrigerant pipes by using the field-supplied insulation material. Insulate the unions and flare nuts at the piping connections completely. Insulate the liquid piping and gas piping completely to avoid decreasing of performance and dewing on the surface of the pipe.

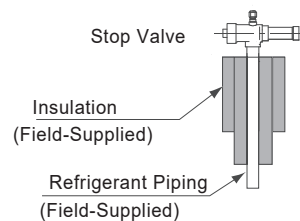

Fig. 7.2 Insulation on Pipes

7.3 Charging Operation

After vacuum pumping, check that the gas and liquid stop valves are completely closed.

Charge additional refrigerant (tolerance: 1.1lbs(0.5kg)) from the check joint of liquid stop valve. If the specified refrigerant quantity can not be charged, follow the procedure below.

- (1) Fully open the stop valve for gas side (In case of heat recovery system, fully open the stop valve for high/low pressure and low pressure gas pipe).
- (2) Operate the compressor in cooling mode and charge refrigerant (tolerance: 1.1lbs(0.5kg)) from the check joint of the liquid stop valve. At this time, the liquid stop valve is slightly opened.
- (3) After refrigerant charge, fully open the stop valve for both liquid and gas sides.

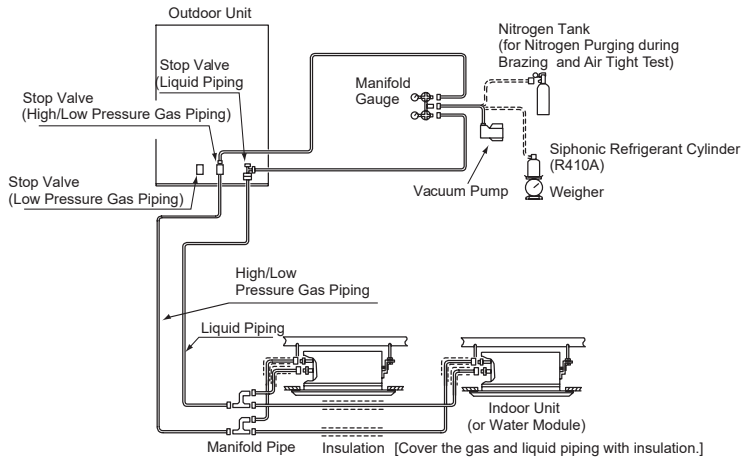

Charge the correct refrigerant quantity. If not, compressor may be damaged due to an excessive or insufficient refrigerant charge.

Refrigerant charging from check joint of gas stop valve may lead to compressor failure. Be sure to charge refrigerant from the check joint of liquid stop valve.

Insulate the liquid piping and gas piping completely to avoid decreasing of performance and dewing on the surface of the pipe.

Insulate the flare nut and union of the piping connection with insulation.

< Heat Recovery System >

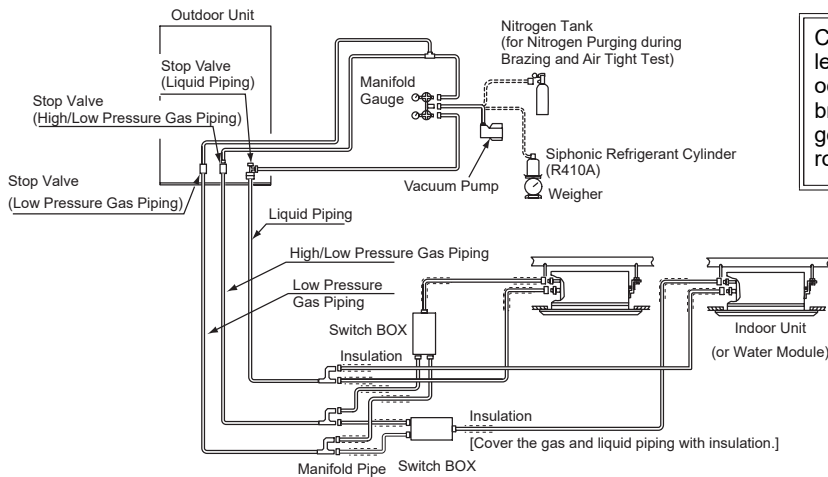

Check to ensure that there is no gas leakage. If a severe refrigerant leakage occurs, it will cause difficulty with breathing or harmful gases would generate when contacting with fire in the room

• Special Attention Regarding Refrigerant Gas Leakage

Pay attention to the critical gas concentration to avoid accidental refrigerant gas leakage before installing air conditioning systems.

$$\frac{R: \text{Totally Charged Refrigerant Quantity in System (lb (kg))}}{V: \text{Room Volume for each Indoor Unit (ft}^3\text{(m}^3\text{))}} \leq C: \text{Critical Concentration } 0.026\text{lbs/ft}^3 \text{ (0.42kg/m}^3\text{)}$$

* This value should be decided according to the each country's regulation such as ISO5149, EN378 and ASHRAE Standard 15. In the case that the calculated concentration is higher than this value, take the following actions:

- 1) Provide a gas leakage detector and exhaust fan controlled by its gas leakage detector.
- 2) Provide effective opening in the wall or door for ventilation to next door so that the critical gas concentration can be maintained lower than the above value. (Provide an opening with area greater than 0.15% of floor surface at the lower part of a door.)

CAUTION

Maximum Permissible Concentration of HFC GAS R410A

The refrigerant R410A is an incombustible and non-toxic gas.

However, if leakage occurs and gas fills a room, it may cause suffocation.

Once leakage occurs, it is a must to take effective actions to make the concentration of R410A lower than 0.42 kg/m³.

2. Calculation of Refrigerant Concentration

(1) Calculate the total quantity of refrigerant R (kg) charged in the system connecting all the indoor units of target rooms.

(2) Calculate the volume of the room installing this unit V (m³).

3. Calculate the refrigerant concentration C (kg/m³) of the room according to the above equation.

Please follow local codes or regulations, if any.

8. Test Run

Test run should be performed according to Item 8.2. And use the Table 8.1 for recording test run.

WARNING

- Do not operate the system until all the check points have been cleared.

As for the test run of indoor unit and water module, check "Installation & Maintenance Manual" attached to the indoor unit and water module.

8.1 Before Test Run

(1) Check to ensure that the refrigerant piping and transmission between outdoor unit, SW BOX, indoor units or water modules are connected to the same refrigerant cycle. If not, it will cause an abnormal operation and a serious accident. Check that the dip switch setting of the refrigerant cycle number and the unit number for the indoor units and water modules apply to the system. Confirm that the dip switch setting on the printed circuit board of the indoor units, water modules and the outdoor units are correct. Especially pay attention to the setting of lift between indoor units and outdoor unit, the refrigerant No. and the terminal resistance.

(2) Check to ensure that the electrical resistance is more than 1MΩ, by measuring the resistance between ground and the terminal of the electrical parts. If not, do not operate the system until the electrical leakage is located and fixed (Refer to "Caution for Insulation Resistance" for details.). Do not impress the voltage on the terminals for transmission.

(3) Check to ensure that each wire, L1, L2, L3 is correctly connected at the power source. If incorrectly connected, the unit will not operate and the remote control switch will indicate the alarm code "05". In this case, check and change the phase of the power source according to the attached sheet on the reverse side of the service cover.

(4) Check to ensure that the switch on the main power source has been ON for more than 4 hours, to warm up the compressor oil by the heater. When powered, the outdoor units will not operate (Stoppage Code d1-22) immediately if it is in protection status due to low compressor oil temperature. In case of operating within 2 hours, release the protection control as follows:

1. Supply power to the outdoor unit.
2. Wait for 30 seconds
3. Push PSW5 on the outdoor PCB more than 3 seconds in order to release the d1-22.
4. In case of using remote control switch for release, push "Air Flow" and "Auto Louver" simultaneously for 3 seconds.

(5) Main Unit Label

In case of the combination of basic units, attach the main unit label on a visible spot of the main unit (outdoor unit A), so that the outdoor unit A can be identified easily. Do not attach the main label on the sub unit (outdoor unit B, C and D).

(6) Water circuit check before test run (In case of the water module is utilized in the system)

(A) Before the test run, please check again if all the water pipe construction is in the proper state.

(B) Inject water into the water module and make sure that the plate type heat exchanger is filled with cycling water; open the water pump and exhaust valve and make sure that air in the unit and pipeline is already exhausted.

(C) Force the running of the water pump, read the value on the pressure gauge and confirm the action of the flow switch to check if the water cycle system is properly installed. (Refer to installation manual of water module)

(D) After the initial test run, please clean the water filter and make sure that the filter mesh is clean and free of impurities.



CAUTION

Caution for Insulation Resistance:

If total unit insulation resistance is lower than $1M\Omega$, the compressor insulation resistance may be low due to retained refrigerant in the compressor. This may occur if the unit has not been used for a long period.

1. Disconnect the cables to the compressor and measure the insulation resistance of the compressor itself. If the resistance value is over $1M\Omega$, then insulation failure has occurred for other electrical parts.
2. If the insulation resistance is less than $1M\Omega$, disconnect the compressor cable from the inverter PCB. Then, turn on the main power to apply current to the crankcase heater. After applying current for more than 3 hours, measure insulation resistance again. (Depending on the air conditions, pipe length or refrigerant conditions, it may be necessary to apply the current for a longer period of time.) Check the insulation resistance and reconnect the compressor.

If the leakage breaker is activated, check the recommended size shown in Table 6.1.



CAUTION

1. Confirm that field-supplied electrical components (main switch fuse, fuse-free breaker, earth leakage breakers, wires, conduit connectors and wire terminals) have been properly selected according to the electrical data given in the Technical Catalog of the unit and ensure that the components comply with national and local codes.
2. Use shielded wires ($>18AWG(0.75mm^2)$) for field wiring to protect from electric noise obstacle (total length of shielded wire shall be less than 3230.8ft.(1000m), and size of shielded wire shall comply with local codes).
3. Check to ensure that the terminal for power source wiring (the voltage of terminals "L1" to "L1" and of shielded wire shall comply with local codes.). If not, some components will be damaged.

8.2 Test Run

(1) Check to ensure that the stop valves of the outdoor unit are fully opened and then start the system.
(In case of the combination module, check that the stop valves of all the connected outdoor units are fully opened.)

NOTE: Low pressure gas is used for heat recovery system only.

(2) Perform the test run of indoor units one by one sequentially and then check corresponding refrigerant piping system and electrical wiring system. (If multiple indoor units operate simultaneously, the system can not be checked for the system accordance.)

(3) Perform the test run according to the following procedure. Ensure that the test run is carried out without any problem.

NOTE: In case of 2-remote control switch (main and sub), firstly perform the test run of the main remote control switch.

a) Set the "TEST RUN" mode by pressing the "MODE" and "CHECK" switch of controller simultaneously for at least 3 seconds.

→ "TEST RUN" is displayed on the LCD.

The total number of the indoor units connected is indicated on the LCD.



unit Example when 5 indoor units are connected.

- Regarding other optional remote control switch (wireless remote control or half-size remote control), follow "Installation & Maintenance Manual" attached to each optional remote control switch and perform the test run.
 - In case that the multiple indoor units operate simultaneously controlled by one remote control switch, check the connected number of indoor unit is indicated on LCD.
In case that the indicated number is not correct, the auto-address function is not performed correctly due to incorrect wiring, the electric noise or etc. Turn OFF the power supply and correct the wiring after checking the following points;
(Do not repeat turning ON and OFF within 10 seconds.)
 - * Power Supply for Indoor Unit is Not Turned ON or Incorrect Wiring.
 - * Incorrect Connection of Connecting Cable between Indoor Units or Incorrect Connection of Controller Cable
 - * Incorrect Setting of Rotary Switch and Dip Switch (The Setting is overlapped.) on the Indoor Units PCB.
- b) Set the operation mode by pressing "MODE" switch.
- c) Press "RUN/STOP" switch.

→ The operation lamp will be turned ON before the test run starts.

2-hour OFF Timer will be set automatically, and "OFF Timer" and "2HR" will be indicated LCD. Although the air flow initial setting is "HI", the setting can be changed.

- Check the operation range according to page I.
 - * Do not touch any of the parts by hand at the discharge side, since the compressor chamber and the pipes at the discharge side are heated to above 194°F(90°C).
 - * DO NOT PUSH THE BUTTON OF THE MAGNETIC SWITCH(ES). It will cause a serious accident.
 - Do not touch any electrical components for at least 10 minutes after turning OFF the main switch.
 - Check that the refrigerant piping setting and electrical wiring setting are for the same system, by operating the indoor unit one by one.
- d) Depress "AUTO LOUVER" switch and check that the louver is activated normally without abnormal sound. Depress "AUTO LOUVER" again so that the louver will stop. If there is abnormal sound, remove the panel and adjust the fitting condition of connection parts in the panel corner cove. Ensure that the panel is mounted correctly to the unit body, otherwise the panel may be deformed.
- e) The temperature control will be invalid though the protection device will be activated during the test run. If alarm occurs, find out the cause of abnormality according to Technical Catalog. And again perform the test run after solving the problems.
- f) According to the label "Checking of Outdoor Unit by 7-segment Display on PCB1" attached to the rear side of the front cover of the outdoor unit, inspect temperature, pressure, operation frequency, and connected indoor unit numbers by the 7-segment displays.
- g) To end the test run, wait for 2 hours or push "RUN/STOP" switch again.

Table 8.1 Test Run and Maintenance Record

MODEL:	SERIAL. No.	COMPRESSOR MFG. No.
CUSTOMER'S NAME AND ADDRESS:		DATE:
THE RESULT OF ALL PERIODIC ROUTINE TESTS:		
1. Is the rotation direction of the indoor fan correct? <input type="checkbox"/>		
2. Is the rotation direction of the outdoor fan correct? <input type="checkbox"/>		
3. Are there any abnormal compressor sounds? <input type="checkbox"/>		
4. Has the unit been operated at least twenty (20) minutes? <input type="checkbox"/>		
5. Check Room Temperature:		
Inlet: <u>No.1 DB /WB °F(°C)</u> <u>No.2 DB /WB °F(°C)</u> <u>No.3 DB /WB °F(°C)</u> <u>No.4 DB /WB °F(°C)</u> Outlet: <u>DB /WB °F(°C)</u> <u>DB /WB °F(°C)</u> <u>DB /WB °F(°C)</u> <u>DB /WB °F(°C)</u> Inlet: <u>No.5 DB /WB °F(°C)</u> <u>No.6 DB /WB °F(°C)</u> <u>No.7 DB /WB °F(°C)</u> <u>No.8 DB /WB °F(°C)</u> Outlet: <u>DB /WB °F(°C)</u> <u>DB /WB °F(°C)</u> <u>DB /WB °F(°C)</u> <u>DB /WB °F(°C)</u>		
6. Check Outdoor Ambient Temperature:		
Inlet: <u>DB °F(°C)</u> <u>WB °F(°C)</u> Outlet: <u>DB °F(°C)</u> <u>WB °F(°C)</u>		
7. Check Refrigerant Temperature:		8. Check Pressure:
Liquid Temperature: _____ °F(°C)		Discharge Pressure: _____ psi(MPa)
Discharge Gas Temperature: _____ °F(°C)		Suction Pressure: _____ psi(MPa)
9. Check Voltage:		
Rated Voltage: _____ V		
Operating Voltage: <u>L₁-L₂</u> _____ V, <u>L₁-L₃</u> _____ V, <u>L₂-L₃</u> _____ V		
Starting Voltage: _____ V		
Phase imbalance $1n - \frac{V}{V_m} =$ _____		
10. Check Compressor Input Running Current:		
Input: _____ kW		
Running Current: _____ A		
11. Is the refrigerant charge adequate? <input type="checkbox"/>		
12. Do the operation control devices operate correctly? <input type="checkbox"/>		
13. Do the safety devices operate correctly? <input type="checkbox"/>		
14. Has the unit been checked for refrigerant leakage? <input type="checkbox"/>		
15. Is the unit clean inside and outside? <input type="checkbox"/>		
16. Are all cabinet panels fixed? <input type="checkbox"/>		
17. Are all cabinet panels free from rattles? <input type="checkbox"/>		
18. Is the filter clean? <input type="checkbox"/>		
19. Is the heat exchanger clean? <input type="checkbox"/>		
20. Are the stop valves open? <input type="checkbox"/>		
21. Does the drain water flow smoothly from the drain pipe? <input type="checkbox"/>		
22. Do the components of the system change and replace? <input type="checkbox"/>		

*Check the installation manual of water module for additional items should be recorded in case of water module is utilized.

The Company is committed to continuous product improvement. We reserve the right, therefore, to alter the product information at any time and without prior announcement.

08.2022

V01